

Owner's Operator And Maintenance Manual

TOP END[®]

Terminator[™] SS

DEALER: THIS MANUAL MUST BE GIVEN TO THE USER OF THE WHEELCHAIR.

USER: BEFORE USING THIS WHEELCHAIR, READ THIS MANUAL AND SAVE FOR FUTURE REFERENCE.



Yes, you can.™

WARNING

DO NOT OPERATE THIS EQUIPMENT WITHOUT FIRST READING AND UNDERSTANDING THIS MANUAL. IF YOU ARE UNABLE TO UNDERSTAND THE WARNINGS, CAUTIONS AND INSTRUCTIONS, CONTACT YOUR INVACARE DEALER OR INVACARE CUSTOMER SUPPORT AT (800) 532-8677 BEFORE ATTEMPTING TO USE THIS EQUIPMENT - OTHERWISE INJURY AND/OR EQUIPMENT DAMAGE MAY RESULT.

SPECIAL NOTES

WARNING/CAUTION notices as used in this manual apply to hazards or unsafe practices which could result in personal injury or property damage.

NOTICE

THE INFORMATION CONTAINED IN THIS DOCUMENT IS SUBJECT TO CHANGE WITHOUT NOTICE.

As a manufacturer of wheelchairs, Invacare endeavors to supply a wide variety of wheelchairs to meet many needs of the end user. However, final selection of the type of wheelchair to be used by an individual rests solely with the user and his/her healthcare professional capable of making such a selection.

WHEELCHAIR TIE-DOWN RESTRAINTS AND SEAT POSITIONING STRAPS

Invacare recommends that wheelchair users **NOT** be transported in vehicles of any kind while in wheelchairs. As of this date, the Department of Transportation has not approved any tie-down systems for transportation of a user while in a wheelchair, in a moving vehicle of any type.

It is Invacare's position that users of wheelchairs should be transferred into appropriate seating in vehicles for transportation and use be made of the restraints made available by the auto industry. Invacare cannot and does not recommend any wheelchair transportation systems.

AS REGARDS RESTRAINTS - SEAT POSITIONING STRAPS - IT IS THE OBLIGATION OF THE DME DEALER, THERAPISTS AND OTHER HEALTHCARE PROFESSIONALS TO DETERMINE IF A SEATING POSITIONING STRAP IS REQUIRED TO ENSURE THE SAFE OPERATION OF THIS EQUIPMENT BY THE USER. SERIOUS INJURY CAN OCCUR IN THE EVENT OF A FALL FROM A WHEELCHAIR.

SAVE THESE INSTRUCTIONS

TABLE OF CONTENTS

SPECIAL NOTES	2
SPECIFICATIONS	5
SECTION 1 - GENERAL GUIDELINES	6
STABILITY	6
OPERATING INFORMATION	6
TIRE PRESSURE AND INFORMATION	8
WEIGHT TRAINING	8
WEIGHT LIMITATION	8
SAFETY/HANDLING OF WHEELCHAIRS	9
SECTION 2 - SAFETY INSPECTION	14
SAFETY INSPECTION CHECKLIST	14
TROUBLESHOOTING	15
MAINTENANCE	15
SECTION 3 - BACK	17
BACK ANGLE ADJUSTMENT	17
FOLDING/UNFOLDING THE BACK	19
ADJUSTING/REPLACING BACK UPHOLSTERY	19
BACK HEIGHT ADJUSTMENT (ADJUSTABLE BACKS ONLY)	23
SECTION 4 - SEAT	24
REPLACING TOP END SEAT UPHOLSTERY	24
REPLACING CUSTOM MANUAL SCREW ON SEAT UPHOLSTERY	25
SECTION 5 - WHEELS	26
REMOVING/INSTALLING REAR WHEELS	26
ADJUSTING QUICK-RELEASE AXLES	27
INSTALLING QUAD-RELEASE AXLES	28
ADJUSTING QUAD-RELEASE HANDLES	28
HANDRIM REPLACEMENT	29
REPAIRING/REPLACING REAR WHEEL, TIRE/TUBE	30
OPENING/CLOSING CLAMPS	30
ADJUSTING REAR WHEEL CAMBER	32
DETERMINING TOE IN/TOE OUT	33
ADJUSTING TOE IN/TOE OUT	34
ADJUSTING WHEELBASE LENGTH (ADJUSTING CENTER OF GRAVITY)	37
ADJUSTING WHEELBASE WIDTH	38
REPLACING AXLE TUBE	39
ADJUSTING THE AXLE TUBE	40
REPLACING/ADJUSTING CASTERS	43
ADJUSTING FRONT CASTER HEIGHT	44
WHEEL LOCK ADJUSTMENT/REPLACEMENT	45

TABLE OF CONTENTS

SECTION 6 - FOOTREST/ANTI-TIPPER	46
ADJUSTING/REPLACING STANDARD FOOTREST	46
INSTALLING/ADJUSTING OPTIONAL CLAMP ON RAISED FOOTREST	47
INSTALLING/ADJUSTING OPTIONAL A4 FOOTREST	47
ANTI-TIPPER REPLACEMENT/ADJUSTMENT	49
SECTION 7 - SUSPENSION	50
ELASTOMERS AND SUSPENSION	50
REPLACING REAR ELASTOMERS	50
REPLACING FRONT ELASTOMERS	52
REMOVING/INSTALLING/REPLACING SUSPENSION TUBES	53
ADJUSTING SEAT-TO-FLOOR HEIGHT	54
REPOSITIONING THE AXLE TUBE	55
REPOSITIONING QUICK RELEASE LEVERS	57
LIMITED WARRANTY	59

SPECIFICATIONS

NOTE: All specifications are approximate.

TERMINATOR SS	
Frame:	Rigid - with Rear Suspension - 4130 Chrome-moly
Seat Width:	12-20-inches - Outside to Outside of SEAT FRAME in 1-inch increments.
Seat Depth:	14 to 18-inches (15-inch Standard)
Seat-to-Floor:	Front - 17 to 21-inches Rear - 14 to 21-inches
Back Style:	Fixed (Standard), Fold Down
Back Height	
Fixed:	8 to 16-inches
Adjustable:	Low - 11 to 14-inches in 1-inch increments. Medium - 14 to 18-inches in 1-inch increments. Tall - 16 to 20-inches in 1-inch increments.
Back Angle:	0°, 3°, 5° or 7°
Rear-Front Caster Distance:	19 to 21-inches (measured from outside of back of frame to center of front caster housing)
Front Caster to Footplate Distance:	3 to 5-inches
Foot Width:	9 to 12-inches (average is 10-inches) (measured between front of footrest bars)
Footrest:	Tubular: 4-inch Height Adjustable (Standard)
Side - Wheel Clearance:	Adjustable 1/2 to 1-1/2-inches
Rear Axle:	Adjustable Axle Position, Quick or Quad-Release
Rear Wheel Camber	
Camber Tube 2000:	0°, 3°, 6°, 12°
A4™ Camber System:	0°, 3°, 6°, 9°, 12°
Rear Wheel Sizes:	24, 25, 26-inch (24-inch Standard) Double walled rim high flange hub (Standard)
Available Tires and Wheels:	24-inch: Primo 25-540 (Standard), 24x1-3/8-inch, Knobby, Spinerger®, KIK® 25-inch: Primo 25-559 (Standard), Knobby, Spinerger, KIK 26-inch: Primo 25-590 (Standard), Spinerger
Handrims:	Aluminum Welded Tab (Standard), Plastic Coated, Dual Grip®
Wheel Locks:	High Mount, Low Mount (Standard)
Front Forks:	Suspension Fork
Caster Size:	3, 4 and 5-inch
Back Upholstery:	U240 Black - Adjustable Tension
Weight:	24 pounds
Shipping Weight*:	40 pounds

**NOTE: 15 x 15-inch seat frame with complete package.*

SPECIFICATIONS

Section I - General Guidelines - includes the following:

Stability

Operating Information

Tire Pressure and Information

Weight Training

Weight Limitation

Safety/Handling of Wheelchairs

STABILITY

STABILITY WARNING

The position of the footrest, camber tube, back angle, the tautness of the back upholstery as well as the user's condition are directly related to the wheelchair's stability. Any change to one (1) or any combination of the five (5) may cause the wheelchair to decrease in stability. Use **EXTREME** caution when using a new seating position. The addition of anti-tippers may be required .

	Footrest Position	Camber Tube	Back Angle	Back Upholstery	User Condition
Footrest Position	●		✓		✓
Camber Tube		●	✓		✓
Back Angle	✓		●	✓	✓
Back Upholstery			✓	●	✓
User Condition	✓	✓	✓	✓	●

NOTE: When changes to the left hand column occur, follow across the chart and refer to the ✓ procedure to maintain the proper stability, safety and handling of the wheel chair.

OPERATING INFORMATION

WARNING

To determine and establish your particular safety limits, practice bending, reaching and transferring activities in several combinations in the presence of a qualified healthcare professional **BEFORE** attempting active use of the wheelchair.

DO NOT attempt to reach objects if you have to move forward in the seat.

DO NOT attempt to reach objects if you have to pick them up from the floor by reaching down between your knees.

DO NOT lean over the top of the back upholstery to reach objects from behind as this may cause the wheelchair to tip over.

DO NOT shift your weight or sitting position toward the direction you are reaching as the wheelchair may tip over.

WARNING

DO NOT tip the wheelchair without assistance.

DO NOT use an escalator to move a wheelchair between floors. Serious bodily injury may occur. Before attempting to transfer in or out of the wheelchair, every precaution should be taken to reduce the gap distance. Turn both casters toward the object you are transferring onto. Also be certain the wheel locks are engaged to prevent the wheels from moving.

DO NOT operate on roads, streets or highways.

DO NOT climb, go up or down ramps or traverse slopes greater than 9°.

DO NOT attempt to move up or down an incline with a water, ice or oil film.

DO NOT attempt to ride over curbs or obstacles. Doing so may cause your wheelchair to turn over and cause bodily harm or damage to the wheelchair.

DO NOT use **ANY** parts, accessories, or adapters other than those authorized by Invacare. Otherwise, the warranty is void.

DO NOT attempt to lift the wheelchair by any removable (detachable) parts. Lifting by means of any removable (detachable) parts of a wheelchair may result in injury to the user or damage to the wheelchair.

DO NOT stand on the frame of the wheelchair.

Check **ALL** allen screws that secure the footrest/raised footrest system to the chair frame **BEFORE** using the wheelchair. **ESPECIALLY** if engaging in **ANY** contact sport.

Anti-tippers MUST BE attached at all times. Inasmuch as the anti-tippers are an option on this wheelchair (you may order with or without the anti-tippers), Invacare strongly recommends ordering the anti-tippers as an additional safeguard for the wheelchair user.

Unless otherwise noted, all service and adjustments should be performed while the wheelchair is unoccupied.

DO NOT use the footplate as a platform when getting in or out of the wheelchair.

ALWAYS wear your seat positioning strap. Inasmuch as the **SEAT POSITIONING STRAP** is an option on this wheelchair (you may order with or without the seat positioning strap), Invacare strongly recommends ordering the seat positioning strap as an additional safeguard for the wheelchair user.

ALWAYS use the handrims for self-propulsion. Inasmuch as the **HANDRIMS** are an option on this wheelchair (you may order with or without the handrims), Invacare strongly recommends ordering the handrims as an additional safeguard for the wheelchair user.

TIRE PRESSURE AND INFORMATION

WARNING

DO NOT use your wheelchair unless it has the proper tire pressure (p.s.i.). **DO NOT** overinflate the tires. Failure to follow these suggestions may cause the tire to explode and cause bodily harm. The recommended tire pressure is on the sidewall of the tire.

Replacement of the tire or tube **MUST** be performed by a qualified technician.

WEIGHT TRAINING

WARNING

Invacare **DOES NOT** recommend the use of its wheelchairs as a weight training apparatus. Invacare wheelchairs have **NOT** been designed or tested as a seat for any kind of weight training. If occupant uses said wheelchair as a weight training apparatus, Invacare shall **NOT** be liable for bodily injury and the warranty is void.

WEIGHT LIMITATION

Invacare's Top End Terminator SS wheelchairs have a weight limitation of 250 lbs.

SAFETY/HANDLING OF WHEELCHAIRS

“Safety and Handling” of the wheelchair requires the close attention of the wheelchair user as well as the assistant. This manual points out the most common procedures and techniques involved in the safe operation and maintenance of the wheelchair. It is important to practice and master these safe techniques until you are comfortable in maneuvering around the frequently encountered architectural barriers.

Use this information only as a “basic” guide. The techniques that are discussed on the following pages have been used successfully by many.

Individual wheelchair users often develop skills to deal with daily living activities that may differ from those described in this manual. Invacare recognizes and encourages each individual to try what works best for him/her in overcoming architectural obstacles that they may encounter, however, ALL WARNINGS and CAUTIONS given in this manual MUST be followed. Techniques in this manual are a starting point for the new wheelchair user and assistant, with “safety” as the most important consideration for all.

STABILITY AND BALANCE

WARNING

ALWAYS wear your seat positioning strap. Inasmuch as the SEAT POSITIONING STRAP is an option on this wheelchair (You may order with or without the seat positioning strap), Invacare strongly recommends ordering the seat positioning strap as an additional safeguard for the wheelchair user.

Anti-tippers MUST BE attached at all times. Inasmuch as the anti-tippers are an option on this wheelchair (You may order with or without the anti-tippers), Invacare strongly recommends ordering the anti-tippers as an additional safeguard for the wheelchair user.

To assure stability and proper operation of your wheelchair, you must at all times maintain proper balance. Your wheelchair has been designed to remain upright and stable during normal daily activities as long as you do not move beyond the center of gravity.

Virtually all activities which involve movement in the wheelchair have an effect on the center of gravity. Invacare recommends using seat positioning straps for additional safety while involved in activities that shift your weight.

DO NOT lean forward out of the wheelchair any further than stability will allow. Make sure casters are pointing in the forward position whenever you lean forward. This can be achieved by advancing the wheelchair and then reversing it in a straight line.

COPING WITH EVERYDAY OBSTACLES

Coping with the irritation of everyday obstacles can be alleviated somewhat by learning how to manage your wheelchair. Keep in mind your center of gravity to maintain stability and balance.

A NOTE TO WHEELCHAIR ASSISTANTS

When assistance to the wheelchair user is required, remember to use good body mechanics. Keep your back straight and bend your knees whenever tilting the wheelchair or traversing curbs, or other impediments.

WARNING

Do not attempt to lift a wheelchair by lifting on any removable (detachable) parts. Lifting by means of any removable (detachable) parts of a wheelchair may result in injury to the user or damage to the wheelchair.

Also, be aware of any removable (detachable) parts. These must NEVER be used to move the wheelchair or as lifting supports, as they may be inadvertently released, resulting in possible injury to the user and/or assistant(s).

When learning a new assistance technique, have an experienced assistant help you before attempting it alone.

PERCENTAGE OF WEIGHT DISTRIBUTION**WARNING**

DO NOT attempt to reach objects if you have to move forward in the seat or pick them up from the floor by reaching down between your knees.

The position of the footrest, camber tube, back angle, the tautness of the back upholstery as well as the user's condition are directly related to the wheelchair's stability. Any change to one (1) or any combination of the five (5) may cause the wheelchair to decrease in stability. Use **EXTREME** caution when using a new seating position. The addition of anti-tippers may be required.

Many activities require the wheelchair owner to reach, bend and transfer in and out of the wheelchair. These movements will cause a change to the normal balance, the center of gravity, and the weight distribution of the wheelchair. To determine and establish your particular safety limits, practice bending, reaching and transferring activities in several combinations in the presence of a qualified health-care professional BEFORE attempting active use of wheelchair.

Proper positioning is essential for your safety. When reaching, leaning, bending forward, it is important to use the front casters as a tool to maintain stability and balance.

LENGTHENING THE WHEELBASE

will increase the stability and maintain standard maneuverability of wheelchair.

SHORTENING THE WHEELBASE

will decrease the stability, increase the maneuverability and distribute additional weight onto the rear wheels.

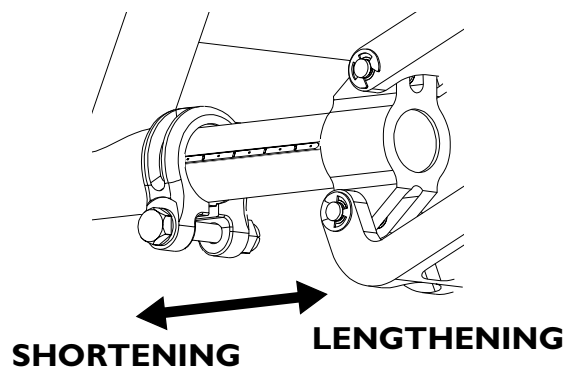
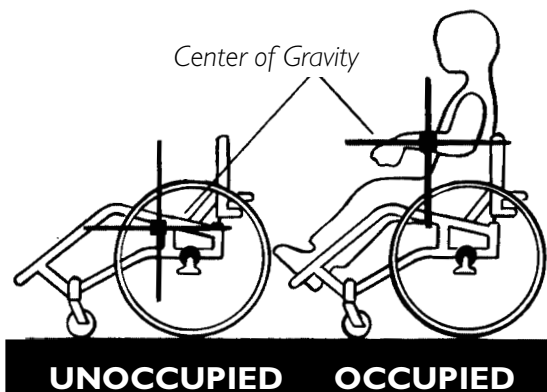

Reaching, Leaning and Bending - Forward.

Position the front casters so that they are extended as far forward as possible and engage wheel locks.

WARNING

DO NOT attempt to reach objects if you have to move forward in the seat or pick them up from the floor by reaching down between your knees.

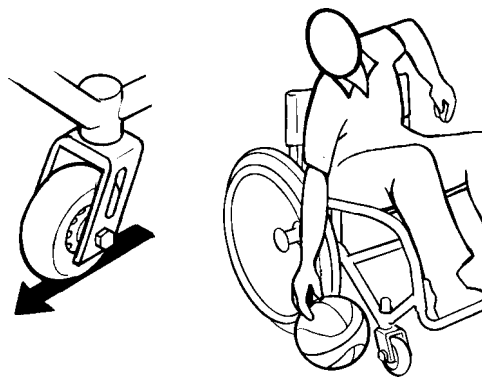

REACHING, LEANING AND BENDING - FORWARD

Reaching, Leaning - Backwards.**WARNING**

DO NOT lean over the top of the back upholstery. This will change your center of gravity and may cause you to tip over.



REACHING, LEANING - BACKWARDS

TIPPING**WARNING**

DO NOT tip the wheelchair without assistance.

DO NOT let the wheelchair drop the last few inches to the ground. This could result in injury to the occupant.

When tipping the wheelchair, an assistant should grasp the back of the wheelchair on a non-removable (non-detachable) part. Inform the wheelchair occupant before tilting the wheelchair and remind him/her to lean back. Be sure the occupant's feet and hands are clear of all wheels and/or pinch points. Apply a continuous motion until the balance point is achieved. At this point, the assistant will feel a difference in the weight distribution. Turn the wheelchair in the desired direction if necessary. Slowly lower the wheelchair in one continuous movement.

TIPPING - CURBS:**WARNING**

Invacare does not recommend that sport wheelchairs be used where traversing curbs present an obstacle. Possible injury to occupant and/or assistant(s) can occur. Transfer to an everyday use wheelchair is recommended if any such obstacles may be encountered.

After mastering the techniques of tipping the wheelchair, use the following method to tackle curbs, short stairs, etc.

Turn the anti-tippers, if equipped, so the wheels are facing UP. Unless the first assistant has exceptional upper body strength, it is recommended that two (2) assistants perform this operation. The second assistant should be positioned at the front of the wheelchair lifting upward on a non-removable (non-detachable) part of the wheelchair frame when lifting the wheelchair and stabilizing the wheelchair when the wheelchair is being lowered to the ground.

The first assistant should stand on the sidewalk and turn the wheelchair so that the rear wheels are against the curb. The wheelchair should be tilted back to the balance point and, in one continuous upward movement, the rear wheels should be pulled up and over the curb. DO NOT return the front casters to the ground until the wheelchair has been pulled backward far enough for the front casters to clear the edge of the curb.

WARNING

When lowering the front casters of the wheelchair, DO NOT let the wheelchair drop the last few inches to the ground. This could result in injury to the occupant and/or damage to the wheelchair.

Roll the wheelchair backward and **SLOWLY** lower the wheelchair in one continuous movement. DO NOT let the wheelchair drop the last few inches to the ground. This could result in injury to the occupant. Turn the anti-tippers so the wheels are facing DOWN.

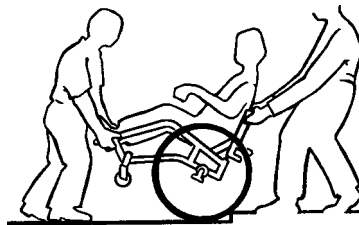
**STAIRWAYS****WARNING**

Concerning stairway access; Invacare does not recommend that these wheelchairs be transported up or down stairways with occupant in the wheelchair. Possible injury to occupant and/or assistant(s) can occur. Transfer to an everyday use wheelchair is recommended.

DO NOT attempt to lift the wheelchair by any removable (detachable) parts. Lifting by means of any removable (detachable) parts of a wheelchair may result in injury to the user or damage to the wheelchair.

Extreme caution is advised when it is necessary to move an occupied wheelchair up or down a stairway. Invacare recommends that, if possible, the user be removed from the wheelchair prior to moving. Invacare recommends using two (2) assistants and making thorough preparations. Make sure to use **ONLY** secure, non-detachable parts for hand-held supports.

Follow this procedure for moving the wheelchair between floors when an elevator is NOT available:

1. If equipped, turn the anti-tippers UP. Refer to SECTION 6 in this manual.
2. After the wheelchair has been tilted back to the balance point, one assistant (in the rear) backs the wheelchair up against the first step, while securely grasping a non-removable (non-detachable) part of the wheelchair for leverage.
3. The second assistant, with a firm hold on a non-detachable part of the framework, lifts the wheelchair up and over the stair and steadies it as the first assistant places one foot on the next stair and repeats procedure.
4. The wheelchair should not be lowered until the last stair has been negotiated and it has been rolled away from the stairway.
5. If equipped, turn the anti-tippers DOWN. Refer to SECTION 6 in this manual.

ESCALATORS? SORRY!

DO NOT use an escalator to move a wheelchair between floors. Serious bodily injury may occur.

TRANSFERRING TO AND FROM OTHER SEATS

WARNING

BEFORE attempting to transfer in or out of the wheelchair, every precaution should be taken to reduce the gap distance. Turn both casters parallel to the object you are transferring onto. Also be certain the wheel locks are engaged to help prevent the wheels from moving.

CAUTION

When transferring, position yourself as far back as possible in the seat. This will prevent damaged upholstery and the possibility of the wheelchair tipping forward.

NOTE: This activity may be performed independently provided you have adequate mobility and upper body strength.

Position the wheelchair as close as possible along side the seat to which you are transferring, with the front casters parallel to it. Remove the armrest, if installed. Engage wheel locks. Shift body weight into seat with transfer.

During independent transfer, little or no seat platform will be beneath you. Use a transfer board if at all possible.

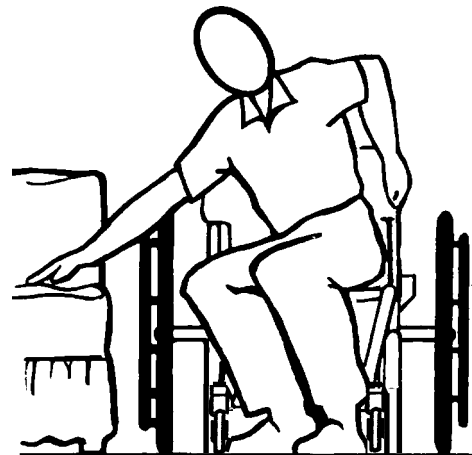

Section 2 - Safety Inspection - includes the following:**Safety Inspection Checklist****Troubleshooting****Maintenance**

NOTE: Every six (6) months, take your wheelchair to a qualified technician for a thorough inspection and servicing. Regular cleaning will reveal loose or worn parts and enhance the smooth operation of your wheelchair. To operate properly and safely, your wheelchair must be cared for just like any other vehicle. Routine maintenance will extend the life and efficiency of your wheelchair. Clean upholstery with mild soap and water or spray disinfectant using a sponge. DO NOT use bleach or wash in a washing machine.

SAFETY INSPECTION CHECKLIST

Initial adjustments should be made to suit your personal body structure and preference. Thereafter follow these maintenance procedures:

ITEM	INITIALLY	INSPECT/ ADJUST WEEKLY	INSPECT/ ADJUST MONTHLY	INSPECT/ ADJUST PERIODICALLY
GENERAL Wheelchair rolls straight (no excessive drag/pull to one side).	X			X
WHEEL LOCKS Do not interfere with tires when rolling. Pivot points free of wear and looseness. Wheel locks easy to engage.	X X X		X X	X
SEAT AND BACK UPHOLSTERY Inspect for rips or sagging. Inspect fastening flaps to ensure they securely latch.	X X		X	X
REAR WHEELS Quick release axles and camber inserts are clean. Adjustable Axle Position Camber Bar is securely tightened. Quick/Quad release axles lock properly. No excessive side movement or binding when lifted and spun.	X X X X	X X	X	X X
HANDRIMS Inspect for signs of rough edges or peeling.	X			X
SPOKES Inspect for bent or broken spokes. All spokes uniformly tight.	X X	X X		
FRONT CASTER Inspect wheel/fork assembly for proper tension by spinning caster; caster should come to a gradual stop. Loosen/tighten locknut if wheel wobbles noticeably or binds to a stop. Wheel bearings are clean and free of moisture. CAUTION: As with any vehicle, the wheels and tires should be checked periodically for cracks and wear, and should be replaced if damaged.	X X X	X	X X	X
TIRES Inspect for flat spots and wear. If pneumatic tires check for proper inflation. CAUTION: As with any vehicle, the wheels and tires should be checked periodically for cracks and wear, and should be replaced if damaged.	X X	X X		
ELASTOMERS Inspect elastomers for proper lubrication.				X
CLEANING Clean upholstery and armrests.	X			X

TROUBLESHOOTING

CHAIR VEERS RIGHT	CHAIR VEERS LEFT	SLUGGISH TURN OR PERFORMANCE	CASTER FLUTTERS	SQUEAKS AND RATTLES	LOOSENESS IN CHAIR	SOLUTIONS
X	X	X	X			Check tires for correct and equal pressure.
		X	X	X	X	Check for loose stem nuts.
				X	X	Check spokes and nipples.
X	X		X			Check that both casters contact the ground at the same time.

MAINTENANCE

MAINTENANCE SAFETY PRECAUTIONS

WARNING

After **ANY** adjustments, repair or service and **BEFORE** use, make sure all attaching hardware is tightened securely - otherwise injury or damage may result.

CAUTION

DO NOT overtighten hardware attaching to the frame. This could cause damage to the frame tubing.

SUGGESTED MAINTENANCE PROCEDURES

1. Before using your wheelchair, make sure all nuts and bolts are tight. Check all parts for damage or wear and replace. Check all parts for proper adjustment.
2. Keep quick/quad-release axles free of dirt and lint to ensure positive locking and proper operation. Refer to ADJUSTING QUICK-RELEASE AXLES or ADJUSTING QUAD-RELEASE HANDLES in SECTION 5 of this manual.

WARNING

DO NOT use **WD-40®**, **3-in-1 oil®**, or other penetrating lubricants on quick-release axles or camber inserts. Otherwise, binding and/or damage to the wheelchair may occur.

3. Clean quick-release axles and camber inserts once (1) a week with a Teflon® lubricant.

WARNING

DO NOT use your wheelchair unless it has the proper tire pressure (p.s.i.).

DO NOT overinflate the tires. Failure to follow these suggestions may cause the tire to explode and cause bodily harm. The recommended tire pressure is on the sidewall of the tire.

4. Recommended tire pressure (p.s.i.) is listed on the sidewall of the tire.

CAUTION

As with any vehicle, the wheels and tires should be checked periodically for cracks and wear, and should be replaced if damaged.

5. The wheels, casters and tires should be checked periodically for cracks and wear, and should be replaced when necessary. Contact a qualified technician or Invacare customer support at the telephone numbers on the back of this manual.
6. Regularly check for loose spokes in the rear wheels. If loose, have them adjusted. Contact a qualified technician or Invacare customer support at the telephone numbers on the back of this manual.
7. Periodically check handrims to ensure they are secured to the rear wheels. Refer to HANDRIM REPLACEMENT in SECTION 5 of this manual.
8. Periodically adjust wheel locks as tires wear. Refer to WHEEL LOCK ADJUSTMENT/REPLACEMENT in SECTION 5 of this manual.
9. Periodically check caster wheel bearings to make sure they are clean and free from moisture. Use a Teflon lubricant if necessary.
10. Periodically lubricate the inside of the elastomers and the shaft of the hex bolt that secures the elastomers to the suspension tube with a silicone based lubricant.
11. Check Upholstery for sagging, rips or tears.
12. Clean Upholstery with mild soap and water.

Section 3 - Back - includes the following:

Back Angle Adjustment

Folding/Unfolding the Back

Adjusting/Replacing Back Upholstery

Back Height Adjustment (Adjustable Backs Only)

WARNING

ALWAYS perform this procedure in the presence of an assistant. The position of the footrest, camber tube, back angle, the tautness of the back upholstery as well as the user's condition are directly related to the wheelchairs stability. Any change to one (1) or any combination of the five (5) may cause the wheelchair to decrease in stability. Use **EXTREME** caution when using a new seating position. The addition of anti-tippers may be required .

After ANY adjustments, repair or service and BEFORE use, make sure all attaching hardware is tightened securely - otherwise injury or damage may result.

BACK ANGLE ADJUSTMENT (FIGURE 1)

NOTE: This procedure is for fold down back chairs only.

NOTE: DO NOT remove the hex screws that secure the back angle bracket to the chair frame and back cane.

NOTE: Perform procedure to both sides at the same time.

1. Loosen the locknuts and hex screws that secure the back angle bracket to the chair frame and the back cane.
2. Loosen the TOP hex screw locknut and slide the TOP hex screw away from the back angle mounting bracket to adjust the cam.
3. Adjust back canes to approximate back angle required.
4. Adjust cam to achieve desired position.

NOTE: An indexing notch has been put on the adjustment cam to help determine cam position for desired back angle adjustment.

5. Reassemble and torque hex screws to 960-1020 inch-pounds (80-85 foot-pounds).

NOTE: As shown in FIGURE 1, the adjustment cam can be rotated to several different positions thus changing the overall back angle relative to the seat rail.

BACK

94° BACK ANGLE TO SEAT RAIL

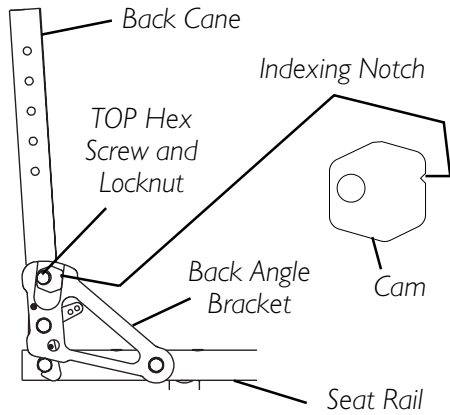

90° BACK ANGLE TO SEAT RAIL

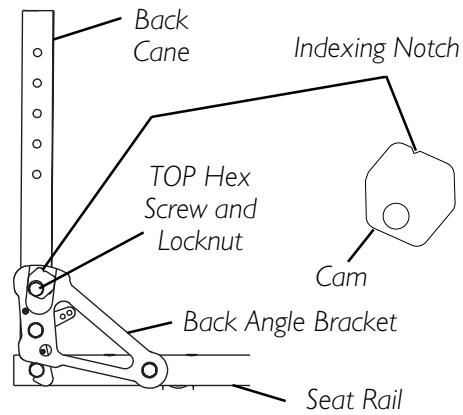

85° BACK ANGLE TO SEAT RAIL

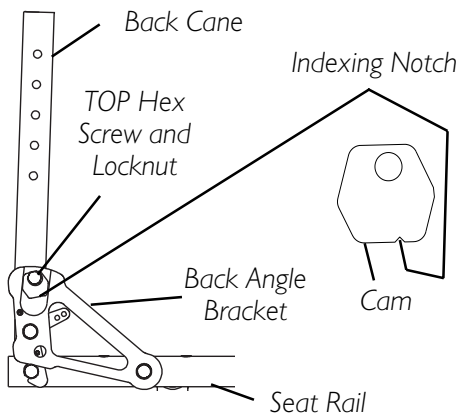

84° BACK ANGLE TO SEAT RAIL

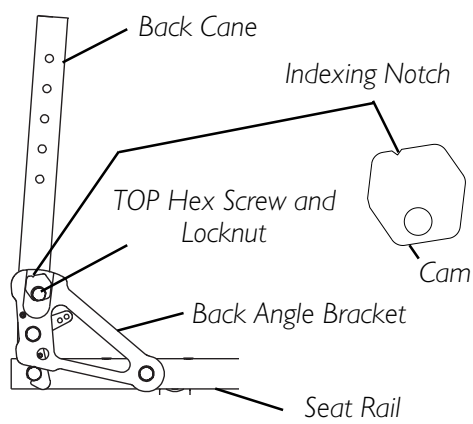

77° BACK ANGLE TO SEAT RAIL

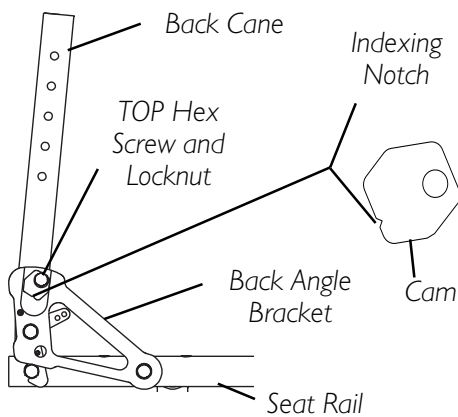

73° BACK ANGLE TO SEAT RAIL

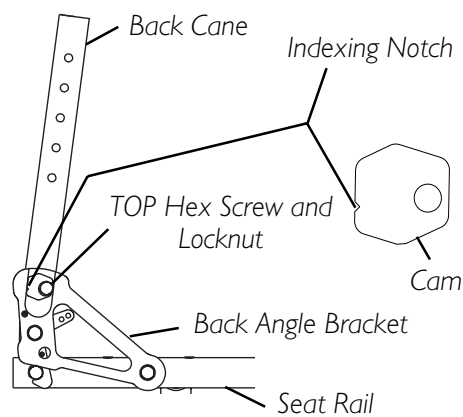

FIGURE I - BACK ANGLE ADJUSTMENT

FOLDING/UNFOLDING THE BACK (FIGURE 2)

NOTE: This procedure is for folding back chairs only.

WARNING

Back MUST be locked securely in place before using the chair.

1. Lift up on the back and pull towards the rear of the chair until it locks into place.
2. To fold the back, pull up on the black nylon cord and push the back forward

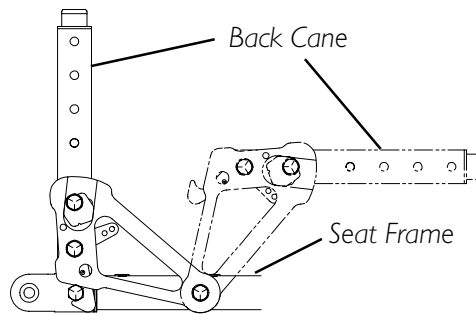

FIGURE 2 - FOLDING/UNFOLDING THE BACK

ADJUSTING/REPLACING BACK UPHOLSTERY

TOP END BACK UPHOLSTERY (FIGURE 3)

WARNING

The back flaps and center upholstery MUST be replaced if hook and loop fastener is worn or DOES NOT secure the flaps to the back center upholstery. If hook and loop fastener is NOT secure, serious injury may result.

Adjusting Top End Back Upholstery.

1. Unlatch the two (2) fastening flaps that secure the top of the back upholstery to the back canes.
2. Align the top of the back upholstery with the fastening flaps ensuring the top of the back upholstery is even with the top of the back canes.
3. Adjust to the desired tautness.

TIGHTER back upholstery will increase the stability and maintain normal maneuverability of the wheelchair because the user is pushed forward in the wheelchair slightly.

LOOSER back upholstery will increase the maneuverability and make the wheelchair more unstable because additional weight is being distributed onto the rear wheels.

4. Securely latch back upholstery to the fastening flaps.

Replacing Top End Back Upholstery.

1. Unlatch the two (2) fastening flaps that secure the top of the back upholstery to the back canes.
2. Remove the fastening flaps from the back canes by lifting straight up.
3. Remove the seat cushion.
4. Separate the bottom of the back upholstery from either the underside or top of the seat upholstery (depending on back style).
5. Install the NEW fastening flaps onto the back canes.

NOTE: The fastening flap with logo is for the left back cane.

NOTE: Right and left is determined by sitting in the wheelchair.

6. Securely latch the bottom of the back upholstery to the fasteners on either the underside or top of the seat upholstery (depending on back style).
7. Adjust the NEW back upholstery to the desired tautness. Refer to ADJUSTING TOP END BACK UPHOLSTERY in this section of the manual.

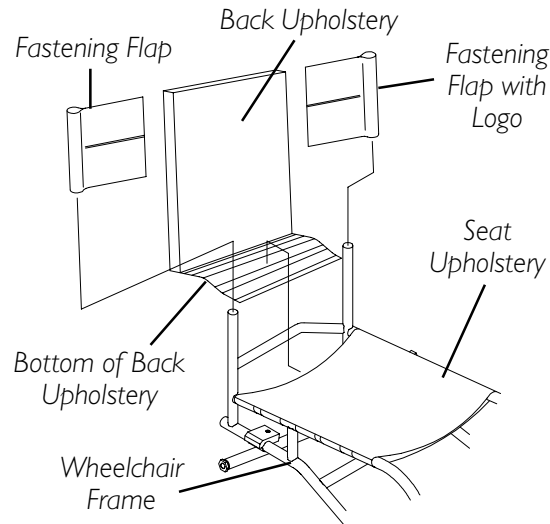

FIGURE 3 - ADJUSTING/REPLACING BACK UPHOLSTERY - TOP END BACK UPHOLSTERY

CUSTOM MANUAL ADJUSTABLE TENSION BACK UPHOLSTERY (FIGURE 4)

The Adjustable Tension Straps.

The straps can be adjusted at various levels of tension to accommodate individual end-users. The bottom two (2) straps can be adjusted tightly to support and/or assist the extensor muscles.

The Back Upholstery Cover.

The back upholstery cover is designed for three (3) reasons:

1. It is a modesty cover.
2. It keeps the cushion from sliding out of the back of the wheelchair.
3. It is a sacral support depending upon how far or tight the flap is pulled under the seat cushion.

Replacing Adjustable Tension Back Upholstery.

1. Remove the back height adjustment screws that secure the back canes to the back uprights.
2. Slide the back canes out of the back uprights.
3. Remove the two (2) screws and washers that secure the EXISTING back upholstery to the back canes.
4. Slide the EXISTING back upholstery down and off the back canes.
5. Stand behind the wheelchair and perform the following:
 - A. Slide anchor loop section of adjustable tension back upholstery up onto the LEFT back cane with the upper grommet hole facing the rear of the wheelchair.
 - B. Slide adjuster strap section of adjustable tension back upholstery up onto the RIGHT back cane with the upper grommet hole facing the rear of the wheelchair.
6. Align the mounting hole in each back cane with the desired mounting hole in each back upright.

NOTE: Both back canes should be adjusted to the same height.

7. Install the two (2) back height adjustment screws through the back upright mounting holes determined in STEP 6 and the back cane mounting holes.
8. Slip adjuster straps through corresponding anchor loops and adjust the back upholstery. Secure with the fastening straps.

WARNING

After the adjustable tension back upholstery has been positioned to the end-user's individual needs, the fastening straps **MUST** be securely fastened **BEFORE** applying the back upholstery cover. The adjustable back should be checked whenever entering the wheelchair to ensure that the fastening straps are securely fastened.

9. Secure the back upholstery cover (fastening strap) to the back of the adjustable back upholstery (fastening strap).
10. Flip the back upholstery cover over the adjustable back upholstery and secure the fastening straps to the front of the adjustable back upholstery.
11. Lay the front portion of the back upholstery cover on the seat pan.
12. Adjust the slack in the back upholstery cover and then secure to the seat pan fastening straps.

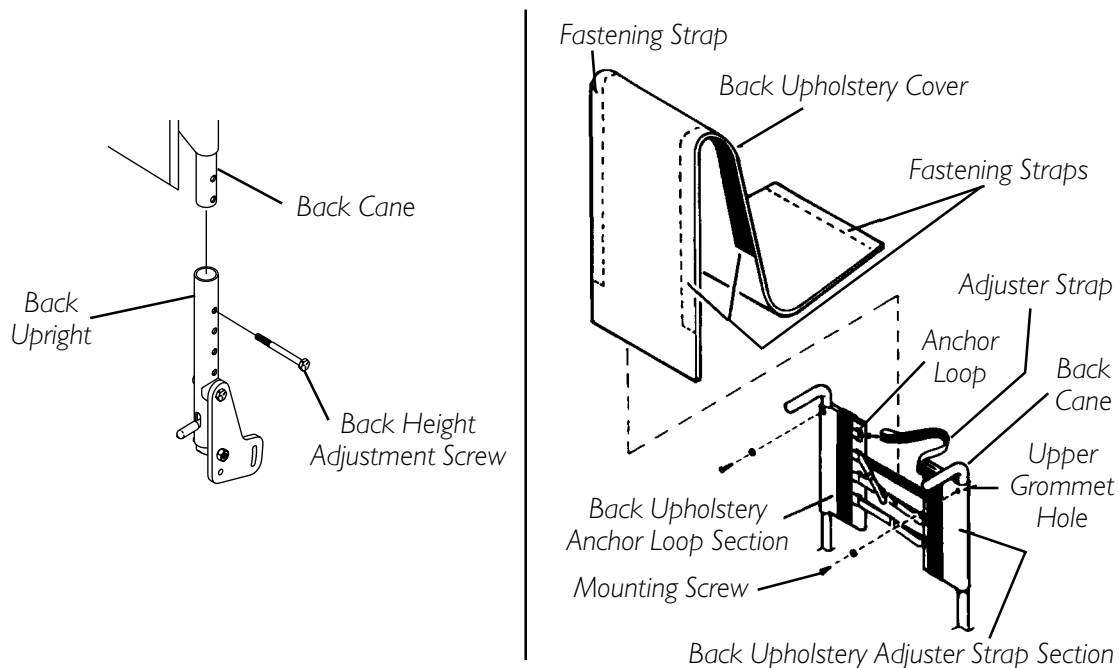

FIGURE 4 - ADJUSTING/REPLACING BACK UPHOLSTERY - CUSTOM MANUAL ADJUSTABLE TENSION BACK UPHOLSTERY

BACK HEIGHT ADJUSTMENT (ADJUSTABLE BACKS ONLY) (FIGURE 5)

NOTE: Observe the tautness of the back upholstery for reinstallation.

1. Unlatch the two (2) fastening flaps that secure the top of the back upholstery to the back canes and remove from the back canes.

WARNING

Push pin **MUST** be protruding through hole in back cane.

Ensure that both back cane inserts are at the same height **BEFORE** reassembling the wheelchair.

2. Press the push pin on the back cane insert tube in and adjust the back height to one (1) of four (4) heights depending on original back height:

ORIGINAL BACK HEIGHT (IN INCHES)			
HOLE NUMBER*	11-14	14-18	16-20
1	11	14	16
2	12	15	17
3	13	16	18
4	14	17	19
**	15	18	20

*NOTE: Holes are numbered from bottom to top for reference only. (There are no numbers on the back canes.)

** NOTE: There is a 1-inch adjustment pin on the back cane insert tube. To raise back to the maximum height, first make adjustment to the back cane inserts.

3. Reinstall the fastening flaps onto the back canes.

NOTE: The fastening flap with logo is for the left back cane.

NOTE: Right and left is determined by sitting in the wheelchair.

4. Adjust the NEW back upholstery to the desired tautness. Refer to ADJUSTING/REPLACING BACK UPHOLSTERY in this section of the manual.

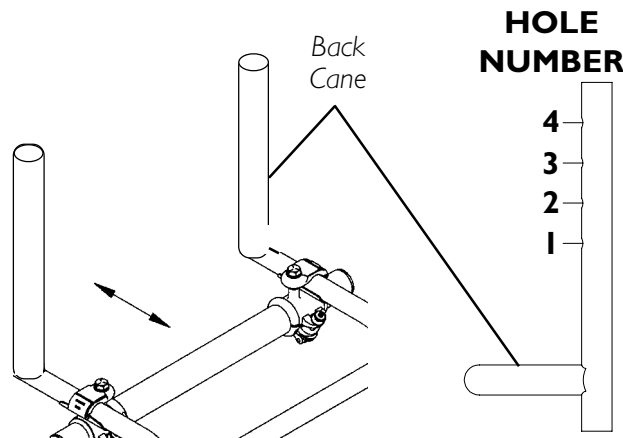

FIGURE 5 - BACK HEIGHT ADJUSTMENT - (ADJUSTABLE BACKS ONLY)

Section 4 - Seat - includes the following:

Replacing Top End Seat Upholstery

Replacing Custom Manual Screw On Seat Upholstery

WARNING

After ANY adjustments, repair or service and BEFORE use, make sure all attaching hardware is tightened securely - otherwise injury or damage may result.

REPLACING TOP END SEAT UPHOLSTERY (FIGURE 1)

WARNING

The seat upholstery and/or cushion **MUST** be cleaned regularly and/or replaced if incontinence is frequent. The risk of pressure sores is significantly higher with seat upholstery that is wet and/or soiled.

1. Remove the seat cushion and back upholstery from the wheelchair.
2. Place the wheelchair onto its two (2) rear wheels.
3. Unlatch the five (5) fastening flaps that secure the seat upholstery to the wheelchair frame.
4. Remove the existing seat upholstery.
5. Place the wheelchair back onto all four (4) wheels.
6. Install the NEW seat upholstery making sure the five (5) fastening flaps hang over the right and left sides of the wheelchair frame.

NOTE: The seat upholstery MUST be positioned with the three (3) double-sided fastening flaps towards the rear of the wheelchair for proper installation of the back upholstery.

NOTE: Make sure the rear retaining flap is BETWEEN the wheelchair frame and the back cane support brackets (adjustable backs only).

NOTE: Right and left is determined by sitting in the wheelchair.

7. Insert the front fastening flaps through the slots on the right and left sides on the underside of the wheelchair frame and securely latch together.
8. Place the wheelchair onto its two (2) rear wheels.
9. Securely latch the four (4) remaining fastening flaps together.

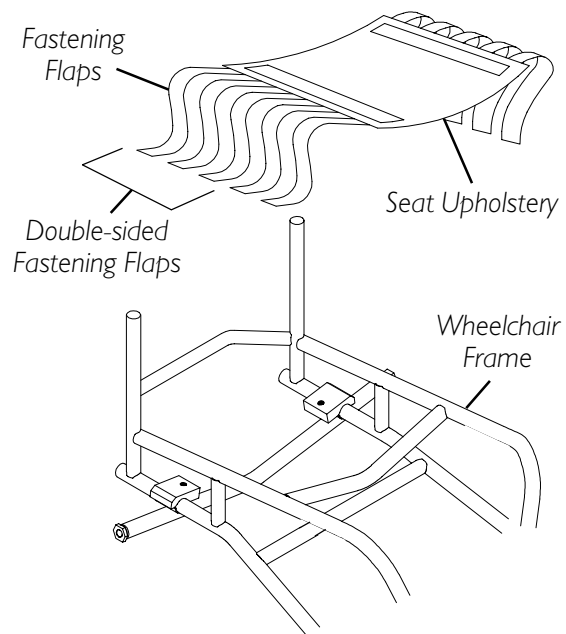
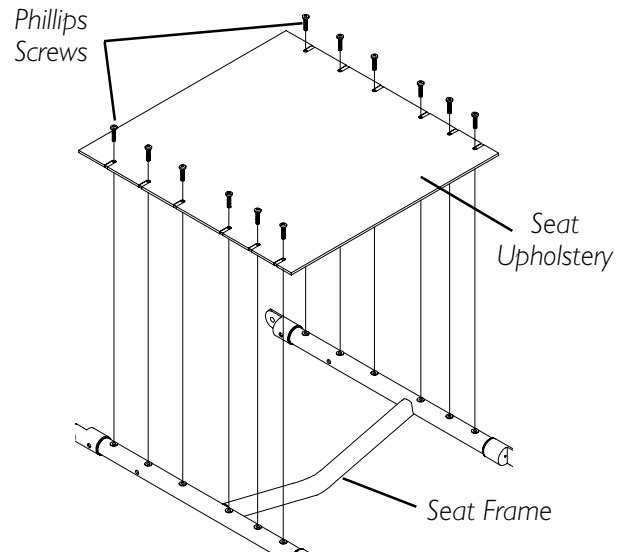

FIGURE 1 - REPLACING TOP END SEAT UPHOLSTERY

REPLACING CUSTOM MANUAL SCREW ON SEAT UPHOLSTERY (FIGURE 2)

1. Remove the seat cushion from the wheelchair.
2. Remove the twelve (12) phillips screws that secure the existing seat upholstery to the seat frame.
3. Remove the existing seat upholstery.



NOTE: Wheelchair frame not shown for clarity.

FIGURE 2 - REPLACING CUSTOM MANUAL SCREW ON SEAT UPHOLSTERY

Section 5 - Wheels - includes the following:

Removing/Installing Rear Wheels
Adjusting Quick-Release Axles
Installing Quad-Release Axles
Adjusting Quad-Release Handles
Handrim Replacement
Repairing/Replacing Rear Wheel, Tire/Tube
Opening/Closing Clamps
Adjusting Rear Wheel Camber
Determining Toe in/Toe out
Adjusting Toe in/Toe out
Adjusting Wheelbase Length (Adjusting Center of Gravity)
Adjusting Wheelbase Width
Replacing Axle Tube
Adjusting the Axle Tube
Replacing Adjusting Casters
Adjusting Front Caster Height
Wheel Lock Adjustment/Replacement

WARNING

After ANY adjustments, repair or service and BEFORE use, make sure all attaching hardware is tightened securely - otherwise injury or damage may result.

REMOVING/INSTALLING REAR WHEELS (FIGURE 1)**CAUTION**

Changing the size of the rear wheels can affect the performance of the wheelchair. Contact Invacare at the telephone numbers on the back of this manual BEFORE changing rear wheel size.

1. Perform one (1) of the following:
 - QUICK-RELEASE** - Push in the tip of the quick-release axle and pull axle and wheel away from the wheelchair.
 - QUAD-RELEASE** - Lift UP on the handle of the quad-release axle and pull axle and wheel away from the wheelchair.
2. Repeat STEP 1 for the opposite rear wheel.
3. Reinstall the rear wheels onto the wheelchair by reversing STEPS 1-2.

WARNING

Pull on the rear wheel to make sure the detent pin and locking pins of the quick/quad-release axle are fully released BEFORE operating wheelchair.

Keep locking pins clean.

- If there is too much movement of the rear wheel assembly in a back and forth motion, refer to ADJUSTING QUICK-RELEASE AXLES or ADJUSTING QUAD-RELEASE HANDLES in this section of the manual.

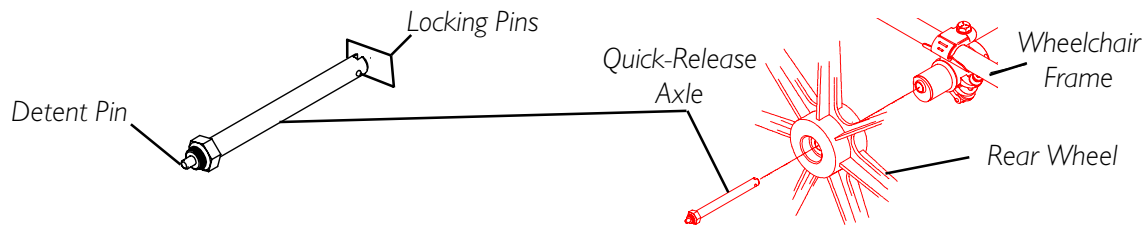

NOTE: Quad-Release Axle not shown. Locking pins the same as Quick-Release Axle.

FIGURE 1 - REMOVING/INSTALLING REAR WHEELS

ADJUSTING QUICK-RELEASE AXLES (FIGURE 2)

- Remove rear wheel and quick-release axle from the wheelchair. Refer to REMOVING/INSTALLING REAR WHEELS in this section of the manual.
- Depress detent pin in the quick-release axle and slide axle through the wheel hub.
- Release detent pin ensuring that the locking pins are fully released.
- Increase or decrease end play by adjusting the locknut on the end of the quick-release axle.
- Reinstall rear wheel onto the wheelchair. Refer to REMOVING/INSTALLING REAR WHEELS in this section of the manual.

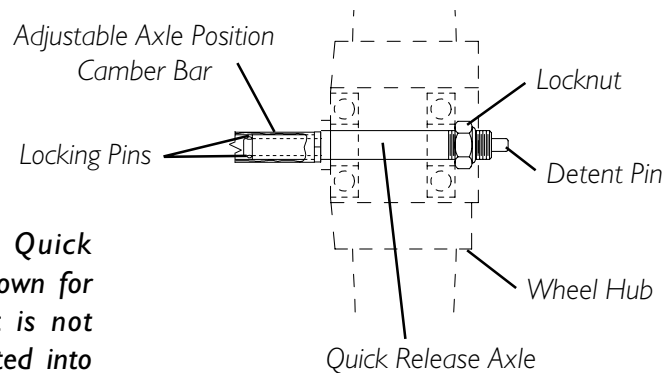

NOTE: End of Quick Release axle is shown for reference only. It is not visible when inserted into camber bar

FIGURE 2- ADJUSTING QUICK-RELEASE AXLES

INSTALLING QUAD-RELEASE AXLES (FIGURE 3)

1. Remove rear wheel and the existing quick-release axle from the wheelchair. Refer to REMOVING/INSTALLING REAR WHEELS in this section of the manual.
2. Remove existing quick-release axle from rear wheel.
3. Insert new quad-release axle through rear wheel hub.
4. Slide locking collar onto quad-release axle until it is snug against rear wheel and tighten securely with allen screw.
5. Reinstall rear wheel and the quad-release axle onto the wheelchair. Refer to REMOVING/INSTALLING REAR WHEELS in this section of the manual.
6. Flip the handle of the quad-release axle down to release the detent pin ensuring that the locking pins are fully released.
7. If detent pin does not fully release, proceed to ADJUSTING QUAD-RELEASE HANDLE IN AND/OR OUT in this section of the manual.
8. Repeat STEPS 1-7 for the opposite rear wheel.

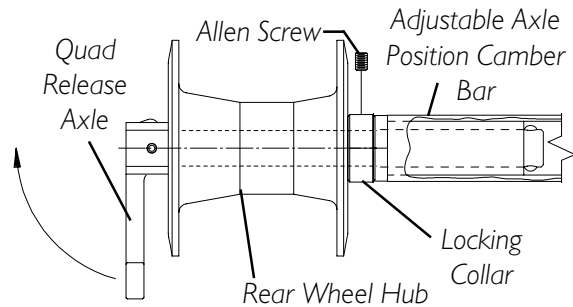

NOTE: End of Quad Release axle shown for reference only. It is not visible when inserted into camber bar

FIGURE 3 - INSTALLING QUAD-RELEASE AXLES

ADJUSTING QUAD-RELEASE HANDLES (FIGURE 4) IN AND/OR OUT

1. Remove rear wheel and the quad-release axle from the wheelchair. Refer to REMOVING/INSTALLING REAR WHEELS in this section of the manual.
2. Loosen the locking screw.
3. Make the following adjustments:

If the quad-release handle is **not releasing the locking pins completely**, rotate the quad-release handle approximately **one-quarter (1/4) turn CLOCKWISE**.

If the quad-release handle **hits the spokes** of the rear wheel when assembled, rotate the quad-release handle approximately **one-quarter (1/4) turn COUNTERCLOCKWISE**.

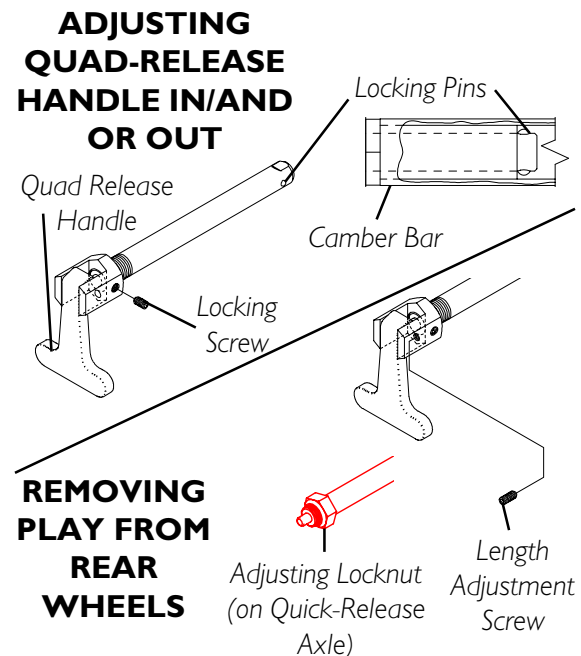

FIGURE 4 - ADJUSTING QUAD-RELEASE HANDLES

4. Tighten the locking screw.
5. Reinstall the rear wheel and quad-release axle onto the wheelchair. Refer to REMOVING/INSTALLING REAR WHEELS in this section of the manual.
6. Flip the handle of the quad-release axle down to release the detent pin ensuring that the locking pins are fully released.
7. Repeat the above procedures until the quad-release axle locks correctly.

REMOVING PLAY FROM REAR WHEELS

NOTE: The adjusting locknut on the quick-release axles originally performed this function.

1. With the rear wheel and quad-release axle still mounted onto the wheelchair, make the following adjustment:
Tighten the length adjusting screw until there is no in and out movement of the quad-release axle and rear wheel.

HANDRIM REPLACEMENT (FIGURE 5)

1. Remove the rear wheel from the wheelchair. Refer to REMOVING/INSTALLING REAR WHEELS in this section of the manual.

WARNING

Tire MUST be FULLY deflated BEFORE any disassembly procedures are performed. Otherwise injury or damage may result.

2. Remove all air from the tube by pressing down on the pin in the center of the valve stem.
3. While carefully holding the tire, tube and rim strip to one side, hold the allen screws and remove the locknuts that secure the handrim to the rear wheel.
4. Remove the EXISTING handrim.
5. Install NEW handrim by reversing STEPS 2-4.

WARNING

DO NOT inflate tire until it is completely assembled. Otherwise injury or damage may result.

6. Inflate tire to correct psi rating on the sidewall of tire.
7. Reinstall rear wheel to the wheelchair. Refer to REMOVING/INSTALLING REAR WHEELS in this section of the manual.
8. Repeat STEPS 1-7 for opposite rear wheel if necessary.

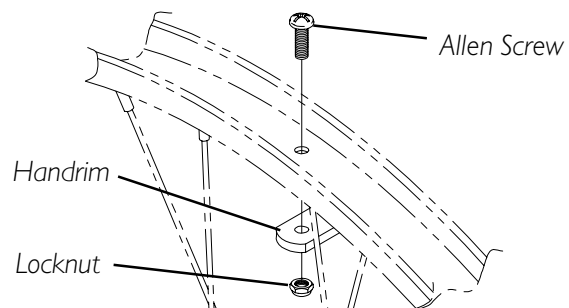

FIGURE 5 - HANDRIM REPLACEMENT

REPAIRING/REPLACING REAR WHEEL, TIRE/TUBE

WARNING

Replacement of the tire or tube **MUST** be performed by a qualified technician.

CAUTION

Changing the size of the rear wheels can affect the performance of the wheelchair. Contact Invacare at the numbers on the back cover **BEFORE** performing this procedure.

*NOTE: If replacing rear wheels with a different size than what was originally on the wheelchair, the front caster height must also be changed to keep the wheelchair frame parallel to the floor. Refer to ADJUSTING CASTER HEIGHT in this section of the manual **ONLY** after contacting Invacare. Anti-tipper height (if applicable) must also be adjusted to maintain 1-1/2 to 2-inch clearance between bottom of the anti-tipper wheels and the floor. Refer to ANTI-TIPPER REPLACEMENT/ADJUSTMENT in SECTION 6 of this manual.*

OPENING/CLOSING CLAMPS (FIGURE 6)

WARNING

QUICK RELEASE LEVERS - Make sure the quick release levers are in the **CLOSED** position **BEFORE** using the wheelchair, otherwise personal injury or damage to the wheelchair may result.

WARNING

STANDARD CAMBER OR RECEIVER TUBE CLAMPS - Make sure the hex screws and locknuts are securely tightened **BEFORE** using the wheelchair, otherwise personal injury or damage to the wheelchair may result.

CAUTION

DO NOT close the quick release levers or tighten the hex screws and locknuts without camber inserts in the axle tube. **Damage to the axle tube will occur.**

CAMBER CLAMPS

1. Perform one (1) of the following to open a camber clamp:
 - A. **QUICK RELEASE LEVERS** - Pull the quick release lever to the open position.
 - B. **STANDARD CAMBER CLAMPS** - Loosen, but do not remove the hex screw and locknut on the camber clamp.
2. Perform one (1) of the following to close a camber clamp:
 - A. **QUICK RELEASE LEVERS** - Tighten the threaded knob to secure the quick release lever. Push the quick release lever on the camber clamps to the closed position.
 - B. **STANDARD CAMBER CLAMPS** - Securely tighten the hex screw and locknut to secure the axle tube.

RECEIVER TUBE CLAMPS

1. Perform one (1) of the following to open a receiver tube clamp:
 - A. **QUICK RELEASE LEVERS** - Pull the quick release levers on the receiver tube clamps to the open position.
 - B. **STANDARD RECEIVER TUBE CLAMPS** - Loosen, but do not remove the hex screws and locknuts on the receiver tube clamps.
2. Perform one (1) of the following to close a receiver tube clamp:
 - A. **QUICK RELEASE LEVERS** - Tighten the threaded knob to secure the quick release lever. Push the quick release lever on the receiver tube clamps to the closed position.
 - B. **STANDARD RECEIVER TUBE CLAMPS** - Tighten the hex screw and locknut on the receiver tube clamp. Torque to 75 in./lbs.

CAMBER CLAMPS

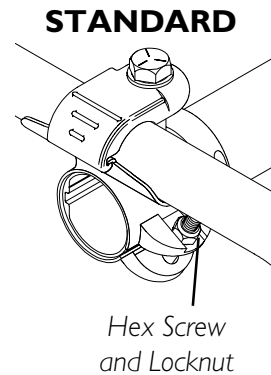
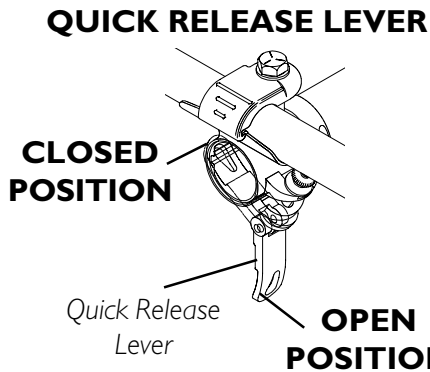

RECEIVER TUBE CLAMPS

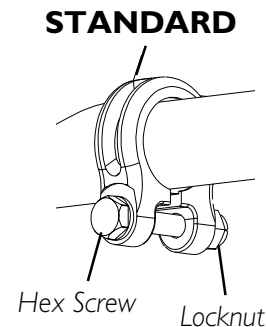
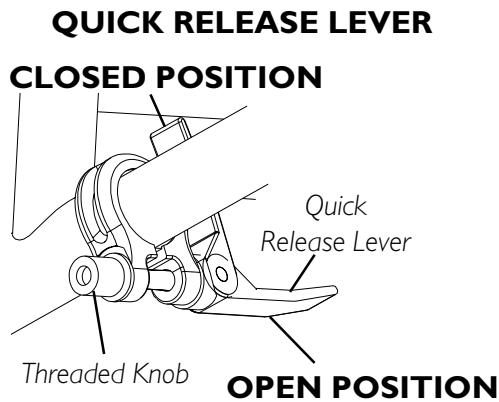

FIGURE 6 - OPENING/CLOSING CLAMPS

ADJUSTING REAR WHEEL CAMBER

CAMBER TUBE 2000

The axle tube must be replaced to change the camber. Refer to REPLACING AXLE TUBE in this section of the manual.

A4 CAMBER SYSTEM (FIGURE 7)

NOTE: Perform this procedure to one (1) side of the wheelchair at a time for ease of adjustment.

1. Open the camber clamp. Refer to OPENING/CLOSING CLAMPS in this section of the manual.
2. Pull one (1) rear wheel with camber insert out of axle tube.
3. Remove the rear wheel from the camber insert.
4. Rotate the camber insert 180°.
5. Reinstall the rear wheel into the camber insert.

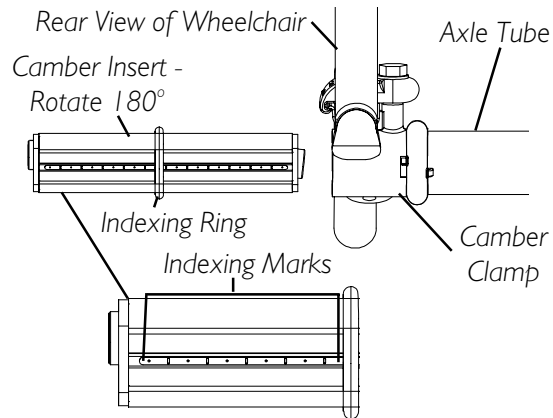

FIGURE 7 - ADJUSTING REAR WHEEL CAMBER - A4 CAMBER SYSTEM

WARNING

NEVER position the camber inserts in the axle tube with more than 3-inches (12 indexing marks showing) of the camber insert outside of the axle tube. The camber inserts will not be securely tightened in the axle tube resulting in possible injury to the user and/or damage to the wheelchair.

6. Position the camber insert to the desired position. Make sure there is no more than 3-inches (12 indexing marks) of the camber inserts outside of the axle tube.
7. Slide the indexing ring on the camber insert until it is flush with the camber clamp.

NOTE: Before using the wheelchair, make sure both camber inserts are set to the same indexing mark. This will make sure the distance between the rear wheel and the wheelchair is the same on both sides.

WARNING

QUICK RELEASE LEVERS - Make sure the quick release levers are pointing towards the rear of the wheelchair and are in the **CLOSED** position **BEFORE** using the wheelchair, otherwise personal injury or damage to the wheelchair may result.

STANDARD - Make sure the hex screws and locknuts are securely tightened **BEFORE** using the wheelchair, otherwise personal injury or damage to the wheelchair may result.

8. Close the camber clamp. Refer to OPENING/CLOSING CLAMPS in this section of the manual.
9. Repeat STEPS 1-8 for opposite side of wheelchair.

10. Reinstall rear wheel to the wheelchair. Refer to REMOVING/INSTALLING REAR WHEELS in this section of the manual.
11. Adjust toe in/toe out of wheelchair. Refer to ADJUSTING TOE IN/TOE OUT in this section of the manual.

DETERMINING TOE IN/TOE OUT (FIGURES 8 AND 9)

1. Inflate all pneumatic tires to recommended tire pressures (p.s.i.)(listed on the sidewall of the tire).
2. Measure the distance between the centerlines at the rear and front of the rear wheels at approximately 12-inches from the ground/floor (FIGURE 8).

NOTE: For optimum accuracy, perform STEP 2 with the wheelchair occupied.

3. Determine difference between two (2) measurements. If **difference** between the **two (2) measurements** is **GREATER** than **1/2-inch (0 ± 1/4-inch for maximum rollability)**, one (1) of two (2) conditions exists:
 - A. If the **back centerline measurement** of the rear wheels is **SMALLER** than the **front centerline measurement** of the rear wheels, a **TOE-OUT** condition exists (FIGURE 9).
 - B. If the **back centerline measurement** of the rear wheels is **LARGER** than the **front centerline measurement** of the rear wheels, a **TOE-IN** condition exists (FIGURE 9).
4. If the difference between the measurements is greater than 1/2-inch, correct the toe-in/toe-out condition. Refer to ADJUSTING TOE-IN/TOE-OUT in this section of the manual.

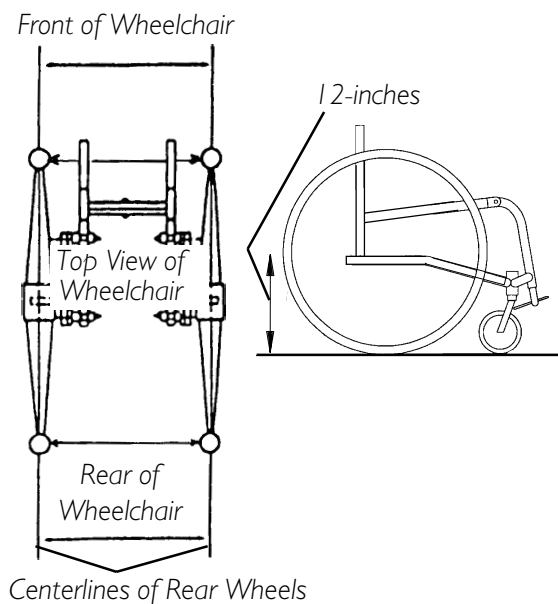

FIGURE 8 - DETERMINING TOE IN/TOE OUT - MEASURING CENTERLINES OF REAR WHEELS

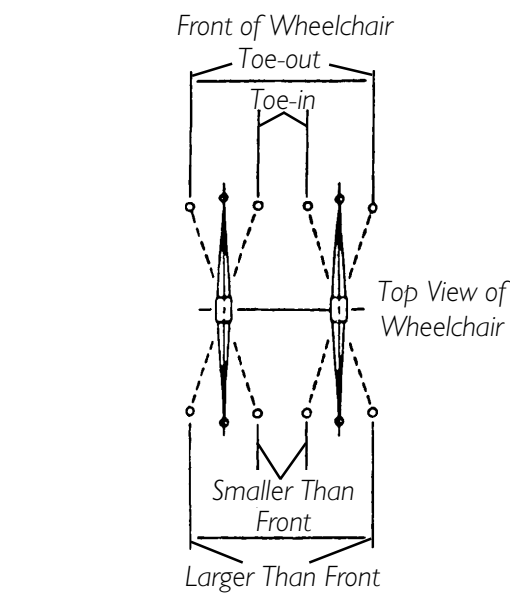

FIGURE 9 - DETERMINING TOE IN/TOE OUT - COMPARING CENTERLINE MEASUREMENTS OF REAR WHEELS

ADJUSTING TOE IN/TOE OUT

CAMBER TUBE 2000 (FIGURE 10)

1. Open the camber clamps. Refer to OPENING/CLOSING CLAMPS in this section of the manual.
2. Slowly rotate the camber tube in either direction until the rear wheels are approximately in a straight line.
3. Close the camber clamps. Refer to OPENING/CLOSING CLAMPS in this section of the manual.
4. Measure the distance between the center lines at the rear and front of the rear wheels at approximately 12-inches from the ground/floor. Refer to DETERMINING TOE IN/TOE OUT in this section of the manual.
5. Repeat STEPS 1-4 until the toe in/toe out measurement is less than 1/2-inch ($0 \pm 1/4$ -inch for maximum rollability).

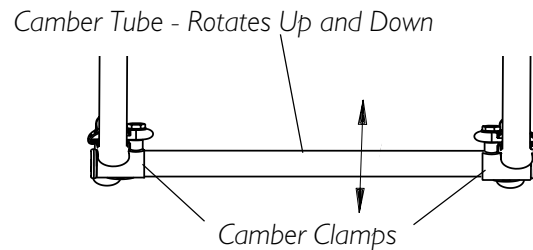

FIGURE 10 - ADJUSTING TOE IN/TOE OUT - CAMBER BAR 2000

A4 CAMBER SYSTEM

Course Adjustment (FIGURE 11).

NOTE: This procedure is required any time the axle tube is moved from the factory set position or is replaced.

NOTE: Make the following adjustment for one (1) camber at a time.

1. Open the camber clamps. Refer to OPENING/CLOSING CLAMPS in this section of the manual.
2. Loosen the phillips screws that secure the adjustment rings to the axle tube.
3. Slowly rotate the axle tube until the rear wheels are approximately in a straight line.

WARNING

QUICK RELEASE LEVERS - Make sure the quick release levers are pointing towards the rear of the wheelchair and are in the **CLOSED** position **BEFORE** using the wheelchair, otherwise personal injury or damage to the wheelchair may result.

WARNING

STANDARD - Make sure the hex screws and locknuts are securely tightened **BEFORE** using the wheelchair, otherwise personal injury or damage to the wheelchair may result.

4. Close the camber clamp. Refer to OPENING/CLOSING CLAMPS in this section of the manual.

5. Measure the distance between the center lines at the rear and front of the rear wheels at approximately 12-inches from the ground/floor. Refer to DETERMINING TOE IN/TOE OUT in this section of the manual.
6. Repeat STEPS 1-4 until the toe in/toe out measurement is less than 1/2-inch ($0 \pm 1/4$ -inch for maximum rollability).
7. Rotate either the right or left adjustment ring until the stop on the ring is at the top of the slot in the camber clamp as shown in FIGURE 11 and securely tighten the phillips screw on the positioned adjustment ring.

NOTE: DO NOT tighten the phillips screw on the other adjustment ring at this time.

NOTE: Repeat STEPS 1-7 of this procedure for the other adjustment ring AFTER repositioning the camber insert. Refer to ADJUSTING REAR WHEEL CAMBER in this section of the manual.

NOTE: When positioning the other adjustment ring, rotate the ring until the stop is at the bottom of the slot in the camber clamp. The right and left stops MUST be positioned opposite of each other or the FINE ADJUSTMENT in this section of the manual will not work correctly.

NOTE: When the left adjustment ring is adjusted to a camber, the right adjustment ring will not touch the camber clamp and when the right adjustment ring is adjusted to the other camber the left adjustment ring will not touch the camber clamp.

NOTE: Rear wheels removed from the drawings for clarity, There is no need to remove rear wheels from the wheelchair during adjustment.

NOTE: Below are two (2) examples of how the adjustment rings can be positioned.

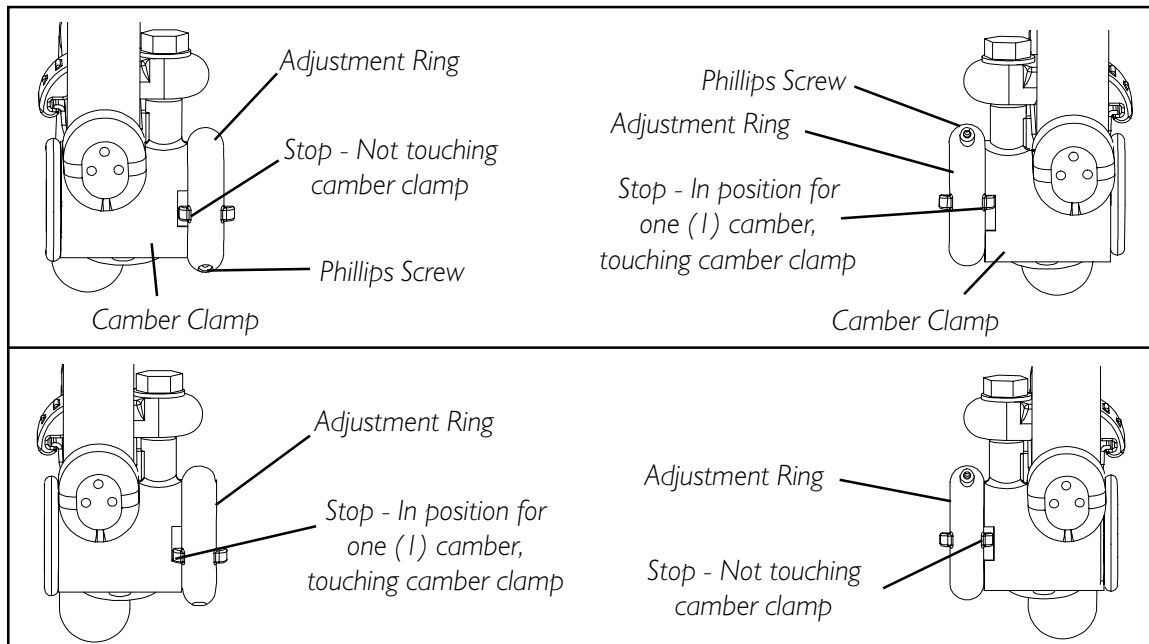
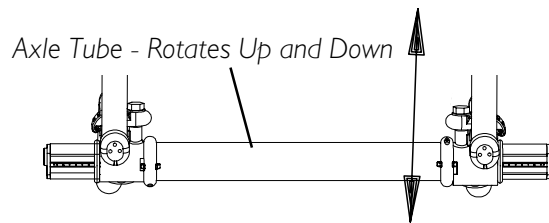

FIGURE 11 - ADJUSTING TOE IN/TOE OUT - A4 CAMBER SYSTEM - COURSE ADJUSTMENT

Fine Adjustment (FIGURE 12).

NOTE: This adjustment is required any time the camber insert is repositioned.

1. Open the camber clamp. Refer to OPENING/CLOSING CLAMPS in this section of the manual.
2. Slowly rotate the axle tube until the stop on the opposite adjustment ring is positioned at the opposite end of the camber clamp.

WARNING

QUICK RELEASE LEVERS - Make sure the quick release levers are pointing towards the rear of the wheelchair and are in the CLOSED position BEFORE using the wheelchair, otherwise personal injury or damage to the wheelchair may result.

STANDARD - Make sure the hex screws and locknuts are securely tightened BEFORE using the wheelchair, otherwise personal injury or damage to the wheelchair may result.

3. Close the camber clamp. Refer to OPENING/CLOSING CLAMPS in this section of the manual.

NOTE: Rear wheels removed from the drawings for clarity, there is no need to remove rear wheels from the wheelchair during adjustment.

NOTE: Below is one (1) example of how the adjustment rings can be positioned.

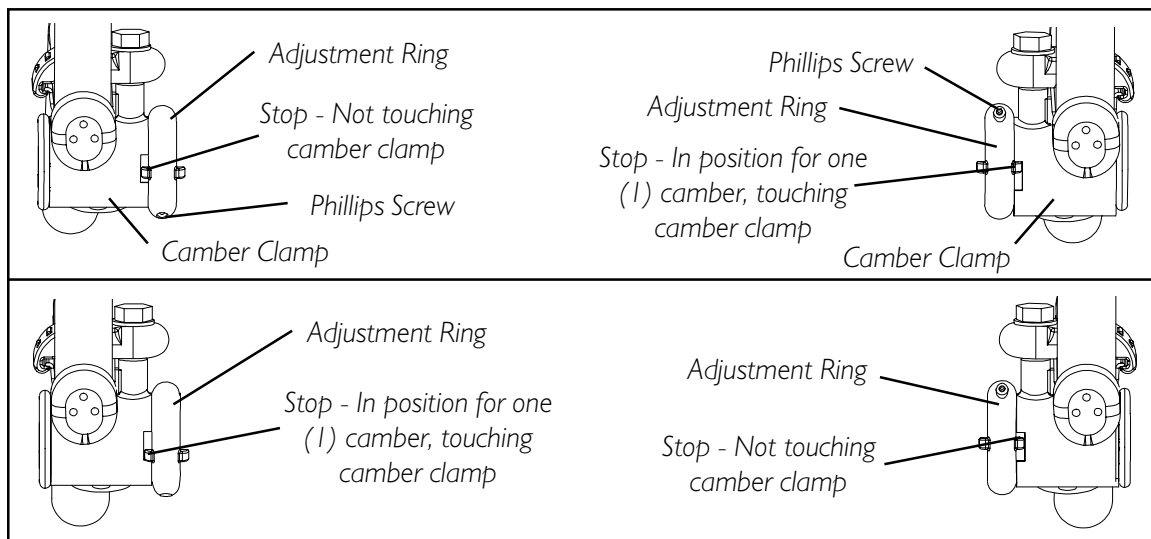
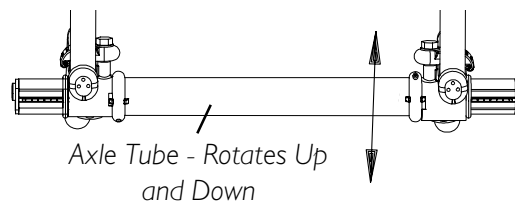

FIGURE 12 - ADJUSTING TOE IN/TOE OUT - A4 CAMBER SYSTEM - FINE ADJUSTMENT

ADJUSTING WHEELBASE LENGTH (ADJUSTING CENTER OF GRAVITY) (FIGURE 13)

WARNING

ALWAYS perform this procedure in the presence of an assistant. The position of the footrest, camber tube, back angle, the tautness of the back upholstery as well as the user's condition are directly related to the wheelchairs stability. Any change to one (1) or any combination of the five (5) may cause the wheelchair to decrease in stability. Use **EXTREME** caution when using a new seating position. The addition of anti-tippers may be required .

1. Open the receiver tube clamps. Refer to OPENING/CLOSING CLAMPS in this section of the manual.

WARNING

LENGTHENING THE WHEELBASE - NEVER position the camber system with the end of the indexing tape (approximately 4-inches) of suspension tube showing. The suspension tubes **WILL NOT** be securely tightened in the wheelchair frame resulting in possible injury to the user and/or damage to the wheelchair. Refer to **FIGURE 13**.

2. Position the camber system to the desired position on the wheelchair frame.

LENGTHENING THE WHEELBASE will increase the stability and maintain standard maneuverability of the wheelchair. Make sure the end of the indexing tape is not showing.

SHORTENING THE WHEELBASE will decrease the stability, increase the maneuverability and distribute additional weight onto the rear wheels.

*NOTE: The performance of the wheelchair will be affected if the two (2) suspension tubes are not set to the same indexing mark. Refer to **FIGURE 13**.*

WARNING

QUICK RELEASE LEVERS - Make sure the quick release levers are pointing towards the inside of the wheelchair and is in the CLOSED position BEFORE using the wheelchair, otherwise personal injury or damage to the wheelchair may result.

STANDARD - Make sure the hex screws and locknuts are securely tightened BEFORE using the wheelchair, otherwise personal injury or damage to the wheelchair may result.

3. Close the receiver tube clamps. Refer to OPENING/CLOSING CLAMPS in this procedure of the manual.
4. Roll the wheelchair before using to make sure there is no excessive drag to either side.

NOTE: If drag to either side occurs, refer to DETERMINING TOE IN/TOE OUT in this section of the manual.

NEVER OPERATE THE WHEELCHAIR WITH BOTH ENDS OF THE INDEXING TAPE SHOWING.

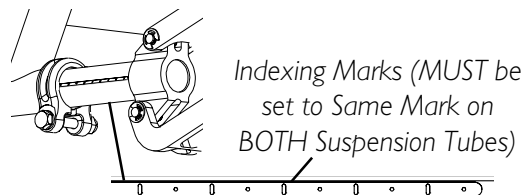

FIGURE 13 - ADJUSTING WHEELBASE LENGTH (ADJUSTING CENTER OF GRAVITY)

ADJUSTING WHEELBASE WIDTH

NOTE: Perform this procedure one (1) side of the wheelchair at a time for ease of adjustment.

CAMBER TUBE 2000 (FIGURE 14)

NOTE: The wheelbase width can be increased/decreased by 1-inch.

1. Remove the rear wheels. Refer to REMOVING/INSTALLING REAR WHEELS in this section of the manual.
2. Torque the axle nut to increase/decrease the wheelbase width.
3. Count the number of threads showing on the axle bolt.

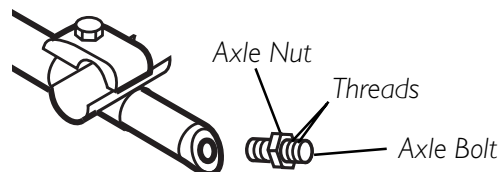

FIGURE 14- ADJUSTING WHEELBASE WIDTH - CAMBER TUBE 2000

NOTE: The number of threads showing on the axle bolt should be equal on both sides of the wheelchair. Otherwise, wheelchair performance may be affected.

4. Repeat STEPS 2-3 for the opposite axle nut and axle bolt.

NOTE: Axle bolt removed from axle tube for clarity. It is not necessary to remove the axle bolt for this procedure.

A4 CAMBER SYSTEM (FIGURE 15)

1. Open the camber clamp. Refer to OPENING/CLOSING CLAMPS in this section of the manual.

WARNING

NEVER position the camber inserts in the axle tube with more than 3-inches (12 indexing marks showing) of the camber insert outside of the axle tube. The camber inserts will not be securely tightened in the axle tube resulting in possible injury to the user or damage to the wheelchair.

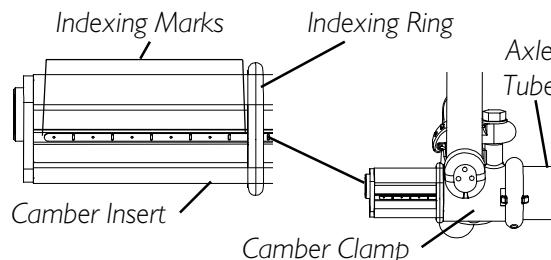

FIGURE 15 - ADJUSTING WHEELBASE WIDTH - A4 CAMBER SYSTEM

2. Position camber insert to the desired position. Make sure there is no more than 3-inches (12 indexing marks showing) of the camber inserts outside of the axle tube.
3. Slide the indexing ring on the camber insert until it is flush with the camber clamp.

NOTE: Before using the wheelchair, make sure both camber inserts are set at the same indexing mark. This will make sure the distance between the rear wheel and the wheelchair is the same on both sides.

WARNING

QUICK RELEASE LEVERS - Make sure the quick release levers are pointing towards the rear of the wheelchair and are in the **CLOSED** position **BEFORE** using the wheelchair, otherwise personal injury or damage to the wheelchair may result.

STANDARD - Make sure the hex screws and locknuts are securely tightened **BEFORE** using the wheelchair, otherwise personal injury or damage to the wheelchair may result.

4. Close the camber clamp. Refer to OPENING/CLOSING CLAMPS in this section of the manual.
5. Repeat STEPS 1-4 for opposite side of wheelchair.

REPLACING AXLE TUBE (FIGURE 16)

NOTE: The camber bar is always mounted to the BOTTOM of the wheelchair frame.

NOTE: There is no need to remove the two (2) camber clamps when replacing the axle tube.

1. **A4 CAMBER SYSTEM ONLY** - Note the position of the camber inserts so they can be installed at the same position in the new axle tube.
2. Open the camber clamps. Refer to OPENING/CLOSING CLAMPS in this section of the manual.
3. Remove the (2) rear wheels. Refer to REMOVING/INSTALLING REAR WHEELS in this section of the manual.
4. **A4 CAMBER SYSTEM ONLY** - Remove the camber inserts positioned in the axle tube.
5. **A4 CAMBER SYSTEM ONLY** - Loosen, but do not remove the two (2) phillips screws that secure the toe adjustment rings to the axle tube.

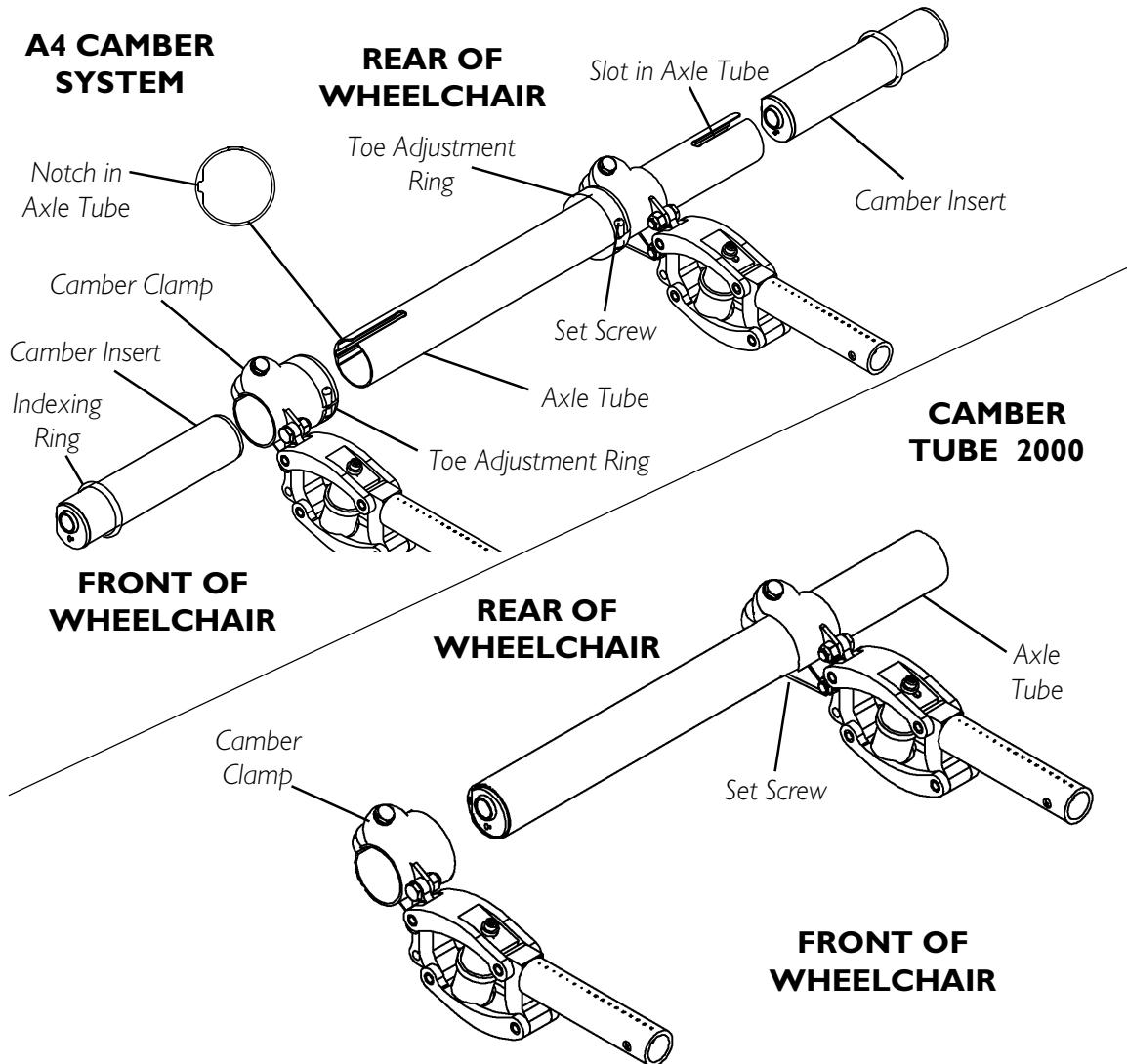

FIGURE 16 - REPLACING AXLE TUBE

6. Pull the existing axle tube through one (1) of the camber clamps.
7. A4 CAMBER SYSTEM ONLY - Remove toe adjustment rings from the existing axle tube.
8. Pull the existing axle tube through the other camber clamp and remove from the wheelchair.
9. Slide the new axle tube through one (1) of the camber clamps.

NOTE: A4 CAMBER SYSTEM ONLY - Make sure the notches in the axle tube are towards the rear of the wheelchair and the slots in the axle tube are facing up.

10. A4 CAMBER SYSTEM ONLY - Install the adjustment rings onto the new axle tube. Make sure the stops on the adjustment rings are facing towards the outside of the wheelchair.

NOTE: Do not tighten the phillips screws that secure the adjustment rings to the axle tube at this time.

11. Slide the new axle tube through the other camber clamp until the axle tube is evenly spaced between the camber clamps.

NOTE: Do not close the camber clamps at this time.

WARNING

NEVER position the camber inserts in the axle tube with more than 3-inches (12 indexing marks showing) of the camber insert outside of the axle tube. The camber inserts will not be securely tightened in the axle tube resulting in possible injury to the user or damage to the wheelchair.

12. A4 CAMBER SYSTEM ONLY - Install camber inserts into the NEW axle tube and slide the camber inserts to the position noted in STEP 1. Make sure there is no more than 3-inches (12 indexing marks) of the camber inserts outside of the axle tube.
13. A4 CAMBER SYSTEM ONLY - Slide the indexing ring on the camber insert until it is flush with the camber clamp.

NOTE: To maximize rollability: Before using the wheelchair, make sure both camber inserts are set to the same indexing notch. This will make sure the distance between the rear wheel and the wheelchair is the same on both sides.

14. Install the rear wheels onto the wheelchair. Refer to REMOVING/INSTALLING REAR WHEELS in this section of the manual.
15. Adjust the axle tube. Refer to ADJUSTING THE AXLE TUBE in this section of the manual.

NOTE: The performance of the wheelchair will be affected if the toe in/toe out of the wheelchair is not correct.

ADJUSTING THE AXLE TUBE

WARNING

QUICK RELEASE LEVERS - Make sure the quick release levers are in the CLOSED position BEFORE using the wheelchair, otherwise injury or damage to the wheelchair may result.

STANDARD - Make sure the hex screws and locknuts are securely tightened BEFORE using the wheelchair, otherwise injury or damage to the wheelchair may result.

CAUTION

A4 CAMBER SYSTEM ONLY - DO NOT close the quick-release levers or tighten the hex screws and locknuts without camber inserts in the axle tube. **Damage to the axle tube will occur.**

NOTE: Stand behind the wheelchair to determine LEFT or RIGHT.

CAMBER TUBE 2000 (FIGURE 17)

1. If necessary, open BOTH camber clamps. Refer to OPENING/CLOSING CLAMPS in this section of the manual.
2. Using an "L" square, rotate the axle tube until the flat edge of the camber tube is at a 90° angle with the ground/floor as shown in FIGURE 17.
3. Close both camber clamps. Refer to OPENING/CLOSING CLAMPS in this section of the manual.
4. Determine the toe in/toe out of the wheelchair. Refer to DETERMINING TOE IN/TOE OUT in this section of the manual.

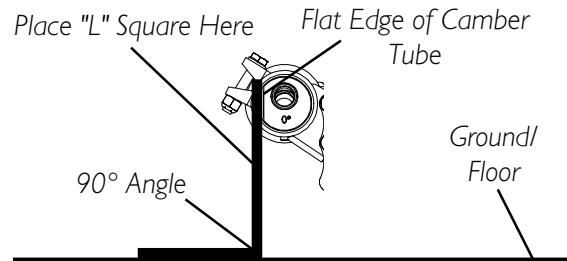

FIGURE 17 - ADJUSTING THE AXLE TUBE - CAMBER TUBE 2000

A4 CAMBER SYSTEM (FIGURE 18)

NOTE: Before performing this procedure, make sure the camber inserts are positioned to the lowest degree of camber. Refer to ADJUSTING REAR WHEEL CAMBER in this section of the manual.

1. If necessary, open BOTH camber clamps. Refer to OPENING/CLOSING CLAMPS in this section of the manual.
2. Loosen the set screw that secures each toe adjustment ring to the axle tube (FIGURE 18).
3. Using an "L" square, rotate the axle tube until the flat edge of the camber insert is at a 90° angle with the ground/floor as shown in FIGURE 18.
4. Close the RIGHT camber clamp. Refer to OPENING/CLOSING CLAMPS in this section of the manual.
5. Rotate the LEFT toe adjustment ring until the tab stops against the LOWER metal tab on the camber clamp.
6. Securely tighten set screw on LEFT toe adjustment ring.
7. Measure the distance between the center lines at the rear and front of the rear wheels at approximately 12-inches from the ground/floor. Refer to DETERMINING TOE IN/TOE OUT in this section of the manual.
8. Perform one (1) of the following:
 - A. **TOE IN/TOE OUT MEASUREMENT IS WITHIN $\pm 1/8$ -INCH** - Proceed to STEP 8.
 - B. **TOE IN/TOE OUT MEASUREMENT IS NOT WITHIN $\pm 1/8$ -INCH** - Repeat STEPS 1-7 until toe in/toe out measurement is within $\pm 1/8$ inch.
9. Open the RIGHT camber clamp. Refer to OPENING/CLOSING CLAMPS in this section of the manual.

10. Reposition the camber inserts to the highest degree of camber. Refer to ADJUSTING REAR WHEEL CAMBER in this section of the manual.
11. Repeat STEP 3.
12. Close the LEFT camber clamp. Refer to OPENING/CLOSING CLAMPS in this section of the manual.
13. Rotate the RIGHT toe adjustment ring until the tab stops against the UPPER metal tab on the camber clamp.
14. Securely tighten set screw on RIGHT toe adjustment ring.
15. Repeat STEP 7.
16. Perform one (1) of the following:
 - A. **TOE IN/TOE OUT MEASUREMENT IS WITHIN $\pm 1/8$ -INCH -**
 - i. Proceed to STEP 17.
 - B. **TOE IN/TOE OUT MEASUREMENT IS NOT WITHIN $\pm 1/8$ -INCH -**
 - i. Repeat STEP 1.
 - ii. Loosen the set screw on the right toe adjustment ring.
 - iii. Repeat STEP 3.
 - iv. Repeat STEPS 12-16 until toe in/toe out measurement is within $\pm 1/8$ inch.
17. If desired, reposition camber inserts to the desired degree of camber. Refer to ADJUSTING REAR WHEEL CAMBER in this section of the manual.

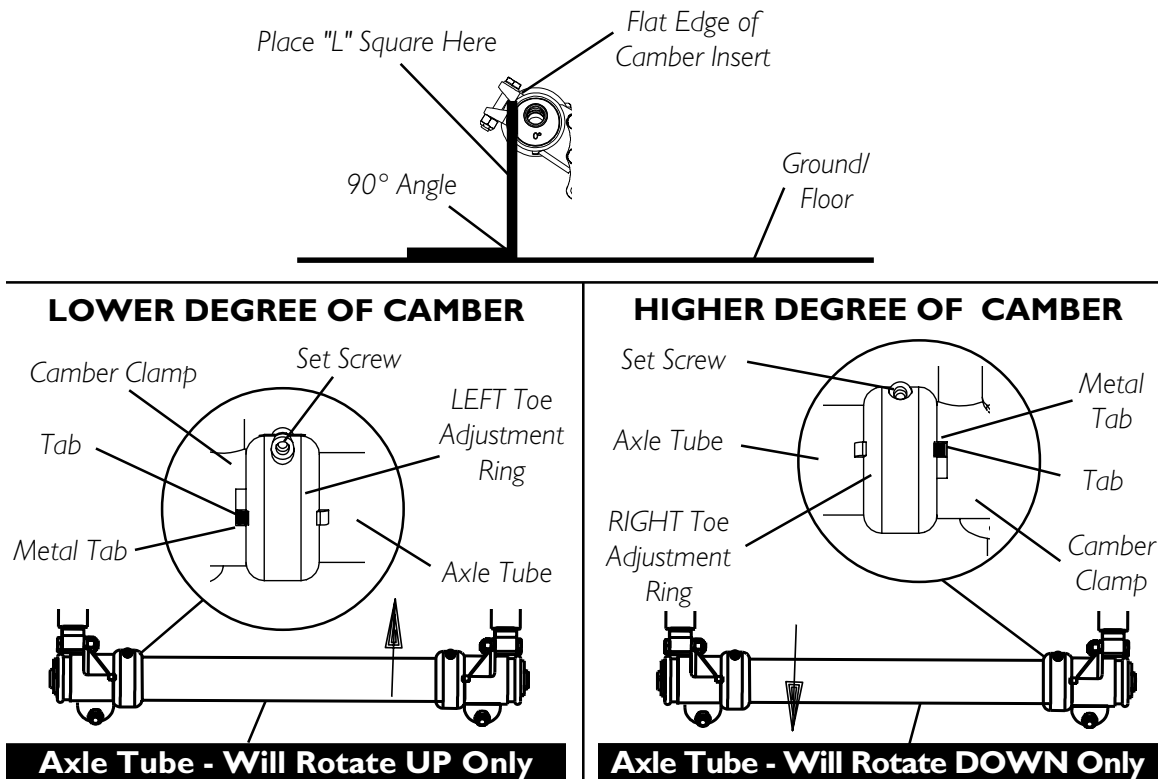

FIGURE 18 - ADJUSTING THE AXLE TUBE - A4 CAMBER SYSTEM

REPLACING/ADJUSTING CASTERS (FIGURE 19)

CAUTION

Changing the size of and/or repositioning the front casters can affect the performance of the wheelchair. Contact Invacare at the telephone numbers on the back of this manual **BEFORE** performing this procedure.

1. Remove the bolt and locknut that secure the front caster to the fork.
2. Remove front caster and axle spacers from fork.
3. Perform one (1) of the following:
 - A. **REPLACING CASTERS** - Install the NEW caster, bolt, locknut and axle spacers onto the fork and securely tighten.
 - B. **ADJUSTING CASTER POSITION (SUSPENSION CASTERS ONLY)** - Install the caster, bolt, locknut and axle spacers onto the fork in the desired mounting position. Tighten securely.
4. Repeat STEPS 1-2 for the opposite caster if necessary.

*NOTE: If replacing front casters with a different size than what was originally on the wheelchair, the front caster height **MUST** be adjusted to keep the wheelchair frame parallel to the floor. Refer to ADJUSTING FRONT CASTER HEIGHT in this section of the manual. The size of the rear wheels may also need adjustment. Refer to REPAIRING/REPLACING REAR WHEEL, TIRE/TUBE in this section of the manual.*

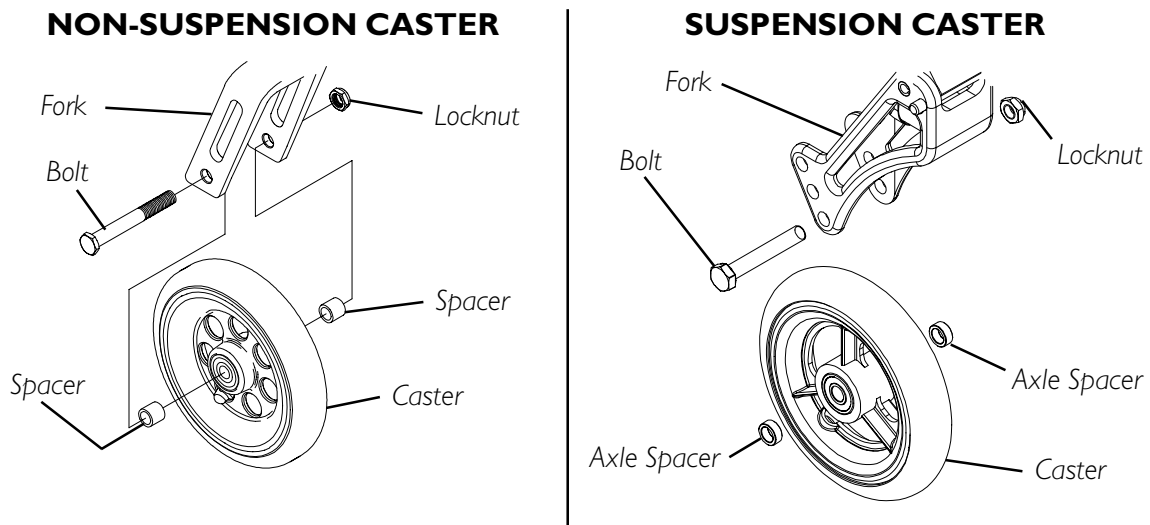

FIGURE 19 - REPLACING/ADJUSTING FRONT CASTERS

ADJUSTING FRONT CASTER HEIGHT (FIGURE 20)

CAUTION

Changing the height of the front casters can affect the performance of the wheelchair. Contact Invacare at the telephone numbers on the back of this manual **BEFORE** performing this procedure.

NOTE: When changing a rear wheel/front caster to a different size and or changing the original degree of camber of the wheelchair, it becomes necessary to adjust the front caster height so the wheelchair frame will remain parallel to the floor.

1. Place the wheelchair on a flat surface.
2. Remove the dust cover on the fork assembly.
3. Remove the locknut that secures the front caster fork to the wheelchair frame.
4. Position a large right triangle or "L" square on the flat surface and against the caster housing that is welded to the wheelchair frame.
5. Adjust the height of the front casters by either adding or removing spacers from the fork stem until the wheelchair frame is parallel with the floor.
6. Reinstall locknut and dust cover onto the wheelchair.
7. Repeat this procedure for the opposite front caster.

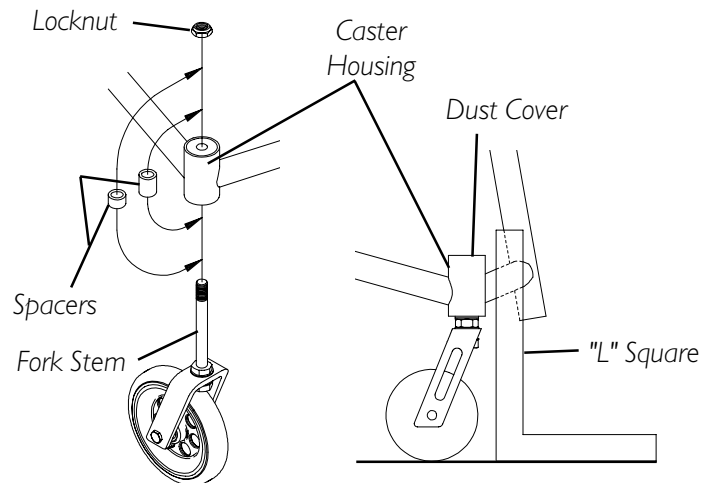

FIGURE 20 - ADJUSTING FRONT CASTER HEIGHT

WHEEL LOCK ADJUSTMENT/REPLACEMENT (FIGURE 21)

NOTE: Invacare recommends LOW mount wheel locks when engaging in any contact sport.

NOTE: Before adjusting or replacing the High/Low mount wheel locks, ensure that the tires are inflated to the recommended psi on the sidewall of the tire.

1. Loosen the locknuts and hex/allen screws that secure the High/Low mount wheel locks to side frame.
2. Perform one (1) of the following:

Replacing the High/Low Mount Wheel Lock:

- A. Remove the locknuts and hex/allen screws and remove existing wheel lock from the wheelchair.
- B. Install the NEW wheel lock and adjust.

Adjusting the High/Low Mount Wheel Lock:

- A. Measure the distance between the **WHEEL LOCK SHOE** and the **REAR WHEEL**.
- B. Slide the wheel lock along the wheelchair until the measurement is between 5/32 and 5/16-inches.
- C. Tighten the wheel lock to the wheelchair frame.
- D. Repeat this procedure for the opposite wheel lock.
- E. Engage the wheel locks and push against the wheelchair to determine if the wheel locks engage the rear wheels enough to hold the occupied wheelchair.
- F. Repeat STEPS A-E until the wheel locks engage the rear wheels enough to hold the occupied wheelchair.

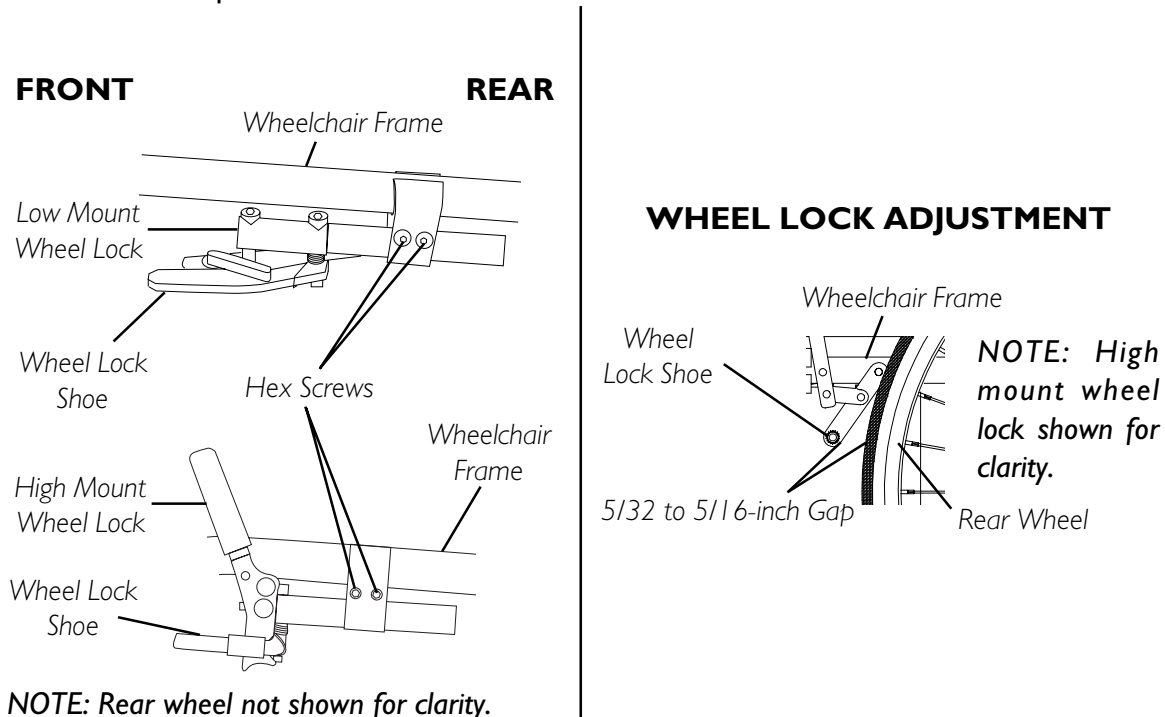

FIGURE 21 - WHEEL LOCK ADJUSTMENT/REPLACEMENT

Section 6 - Footrest/Anti-tipper - includes the following:

Adjusting/Replacing Standard Footrest

Installing/Adjusting Optional Clamp on Raised Footrest

Installing/Adjusting Optional A4 Footrest

Anti-Tipper Replacement/Adjustment

WARNING

After **ANY** adjustments, repair or service and **BEFORE** use, make sure all attaching hardware is tightened securely - otherwise injury or damage may result.

ALWAYS perform this procedure in the presence of an assistant. The position of the footrest, camber tube, back angle, the tautness of the back upholstery as well as the user's condition are directly related to the wheelchairs stability. Any change to one (1) or any combination of the five (5) may cause the wheelchair to decrease in stability. Use **EXTREME** caution when using a new seating position. The addition of anti-tippers may be required.

Check **ALL** allen screws that secure the footrest/raised footrest system to the wheelchair frame to make sure they are securely tightened **BEFORE** using the wheelchair, **ESPECIALLY** if engaging in **ANY** contact sport.

The footrest assembly **MUST** be at least 1-3/4-inches above the ground/ floor to avoid hitting protruding objects when using this wheelchair.

ADJUSTING/REPLACING STANDARD FOOTREST (FIGURE 1)

1. Loosen the two (2) allen screws that secure the footrest to the wheelchair frame.

IF REPLACING THE FOOTREST:

1. Remove **EXISTING** footrest.
2. Install **NEW** footrest.

WARNING

The standard footrest has an open hoop. A footplate cover is recommended for wheelchair users that have leg spasticity or whose feet have a possibility of falling through the footrest hoop. A calf strap is provided with each wheelchair to prevent the feet from slipping backwards off of the footrest. Be sure the calf strap is secure when using the wheelchair.

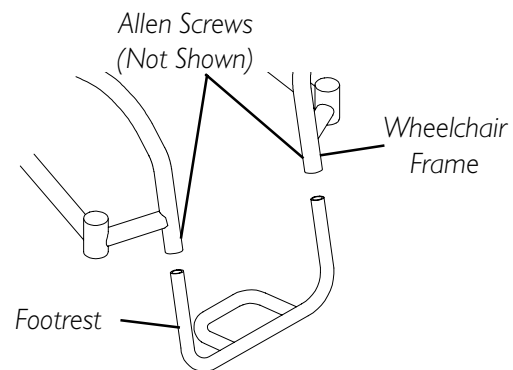

FIGURE 1 - ADJUSTING/REPLACING STANDARD FOOTREST

IF REPLACING OR ADJUSTING THE FOOTREST:

1. Position **NEW/EXISTING** footrest to desired height.
2. Tighten the two (2) allen screws that secure the footrest to the wheelchair frame.

INSTALLING/ADJUSTING OPTIONAL CLAMP ON RAISED FOOTREST (FIGURE 2)

INSTALLING

1. Install the two (2) half clamps onto either side of the wheelchair frame approximately 2-inches above existing footrest with two (2) allen screws provided.
2. Repeat for the opposite side of the wheelchair.
3. Slide the clamp on raised footrest into the half clamps to the desired height.
4. Securely tighten the four (4) allen screws.

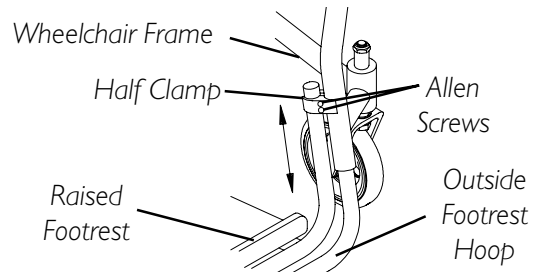

FIGURE 2 - INSTALLING/ADJUSTING OPTIONAL CLAMP ON RAISED FOOTREST

ADJUSTING

1. Loosen the four (4) allen screws.
2. Adjust clamp on raised footrest to the desired height.
3. Securely tighten all four (4) allen screws.

INSTALLING/ADJUSTING OPTIONAL A4 FOOTREST (FIGURE 3)

REPLACING THE FOOTREST

1. Loosen, but do not remove the two (2) allen screws that secure the footrest to the wheelchair frame.
2. Slide the EXISTING footrest tubes out of the wheelchair frame and install NEW footrest by reversing this step.
3. Position the NEW footrest to a determined height.
4. Tighten the two (2) allen screws that secure the footrest to the wheelchair frame.
5. Adjust the footplate to the desired position. Refer to FOOTPLATE ANGLE ADJUSTMENT and/or FOOTPLATE DEPTH ADJUSTMENT in this section of the manual.

FOOTPLATE ANGLE ADJUSTMENT

1. Loosen, but do not remove the four (4) flat screws and locknuts that secure the footplate to the two (2) footrest tubes.
2. Position the footplate to the necessary angle to accommodate the user.
3. Retighten the four (4) flat screws and locknuts.

NOTE: The locknuts should be placed in the channel of the footplate half clamp.

FOOTPLATE DEPTH ADJUSTMENT

1. Loosen, but do not remove the four (4) flat screws and locknuts that secure footplate to the footrest tubes.

NOTE: Observe the angle of footplate for reinstallation.

2. Move the footplate to one (1) of two (2) positions to accommodate the user.
3. Retighten the four (4) flat screws and locknuts.

NOTE: The settings for positioning the footplates on the half-clamps may vary for each end-user.

NOTE: The locknuts should lie in the channel of the footplate half clamp.

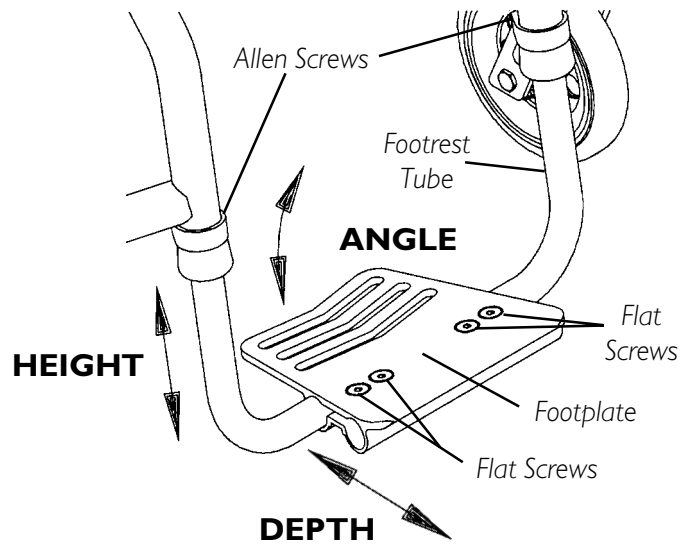

FIGURE 3 - INSTALLING/ADJUSTING OPTIONAL A4 FOOTREST

ANTI-TIPPER REPLACEMENT/ADJUSTMENT (FIGURE 4)**WARNING**

Anti-tippers **MUST BE** attached at all times. Inasmuch as the **ANTI-TIPPERS** are an option on this wheelchair (You may order it with or without the anti-tippers), Invacare strongly recommends ordering the anti-tippers as an additional safeguard for the wheelchair user.

ALL WHEELCHAIRS EXCEPT X-TERMINATOR - Anti-tippers **MUST** be fully engaged. Ensure the the release button of the anti-tipper fully protrudes out of the hole in the anti-tipper socket.

Ensure both anti-tippers are adjusted to the same height.

REPLACEMENT

1. Press in the two (2) push pins that secure the EXISTING anti-tipper to the wheelchair frame and remove the EXISTING anti-tipper from the wheelchair.
2. Insert the NEW anti-tipper into the wheelchair. Make sure the push pins are fully released.

NOTE: A 1-1/2 to 2-inch clearance between the bottom of the anti-tipper wheels and the floor must be maintained.

3. Adjust the anti-tippers. Refer to ADJUSTMENT in this section of the manual.

ADJUSTMENT

*NOTE: If the rear wheel size is changed or the position of the adjustable axle camber bar is changed, the anti-tippers **MUST** be readjusted to maintain a 1-1/2 to 2-inch clearance between the bottom of anti-tipper wheels and floor.*

1. Press in the two (2) push pins that secure the anti-tipper wheels to the anti-tipper bar.
2. Adjust height of the anti-tip wheels to between 1-1/2 and 2-inches (one [1] of four [4] positions) off of the floor. Make sure the push pins are fully released.

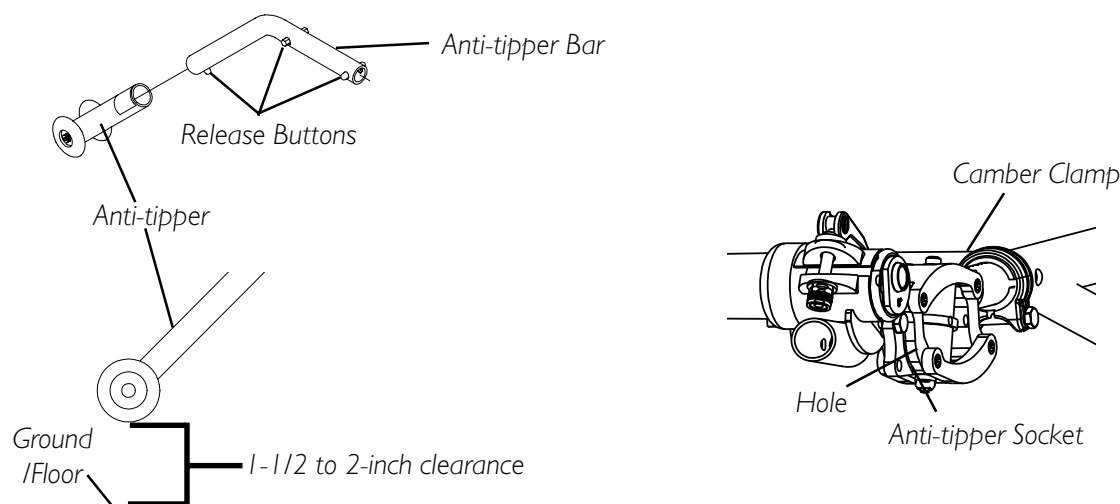
**FIGURE 4 - ANTI-TIPPER REPLACEMENT/ADJUSTMENT**

Section 7 - Suspension - includes the following:

Elastomers and Suspension

Replacing Rear Elastomers

Replacing Front Elastomers

Removing/Installing/Replacing Suspension Tubes

Adjusting Seat-to-Floor Height

Repositioning the Axle Tube

Repositioning Quick Release Levers

WARNING

After ANY adjustments, repair or service and BEFORE use, make sure all attaching hardware is tightened securely - otherwise injury or damage may result.

ELASTOMERS AND SUSPENSION

CAUTION

Weather conditions may affect elastomers. Invacare recommends that elastomers be replaced once a year, otherwise the performance of the wheelchair may be affected.

NOTE: The performance of the wheelchair will be affected if elastomers ARE NOT the same on BOTH SIDES of the wheelchair.

NOTE: If elastomers squeak, lubricate the ends of the elastomers and the shaft of the mounting bolt that secures the elastomers to the suspension tube with a silicone based lubricant.

REPLACING REAR ELASTOMERS (FIGURE 1)

1. Refer to the following chart to determine the elastomers required for the user's weight.

NOTE: Periodically review the following chart to make sure the rear suspension still corresponds to user's weight.

USER'S WEIGHT (IN LBS.)	ELASTOMERS REQUIRED (PER SIDE)	
	UPPER	LOWER
Less Than 100	BLUE	BLUE
101 - 140	BLUE	BLACK
141 - 180	BLACK	BLACK
181 - 220	BLACK	PURPLE
221 - 250	PURPLE	PURPLE

NOTE: The performance of the wheelchair will be affected if elastomers DO NOT correspond to user's weight.

- Remove the mounting bolt and locknut that secure the nylon washers, EXISTING UPPER and LOWER elastomers and recessed spacer to the suspension arms.
- Reinstall the nylon washers, NEW UPPER and LOWER elastomers determined in STEP 1 and recessed spacer into the suspension tube with the mounting bolt. Refer to FIGURE 1 for hardware orientation.

4. Install the locknut onto the mounting bolt.

NOTE: It may be necessary to compress the rear suspension system to install the locknut onto the mounting bolt.

5. Tighten the locknut until three (3) threads can be seen on the end of mounting bolt.
6. Ensure wheel locks engage properly. Refer to WHEEL LOCK ADJUSTMENT/REPLACEMENT in SECTION 5 of the manual.

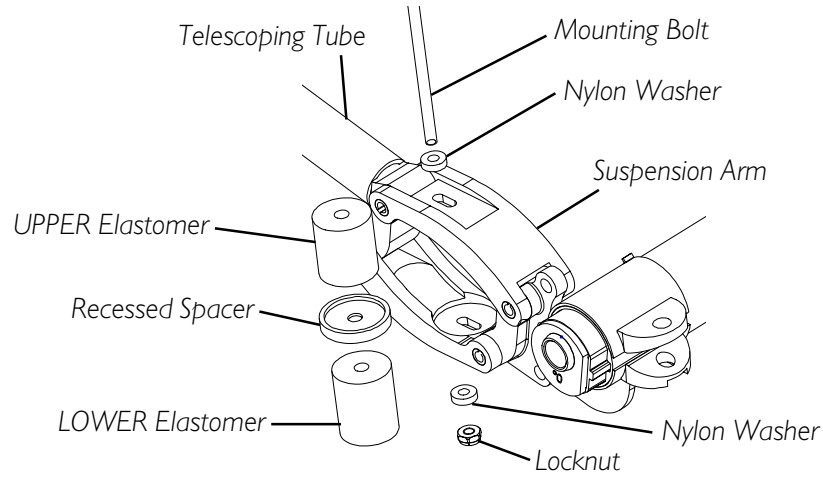

FIGURE I - REPLACING REAR ELASTOMERS

REPLACING FRONT ELASTOMERS (FIGURE 2)

WARNING

Ensure the detent ball protrudes past the fork **BEFORE** use. Otherwise, injury or damage may occur.

1. Remove the bolt and locknut securing the fork to the fork stem (DETAIL "C").
2. Remove the EXISTING elastomer from the fork (DETAIL "A").
3. Position one end of the NEW elastomer into the fork stem recess and the other end into the fork recess (DETAIL "A").

NOTE: Ensure the ends of the elastomer sit flush in the fork and fork stem recesses.

4. Hold and squeeze the fork and fork stem together (DETAIL "B").
5. Insert the bolt through the mounting holes in the fork to secure the elastomer to the fork.

NOTE: The bolt should be inserted from the OUTSIDE of the wheelchair, so the locknut will be on the INSIDE of the wheelchair.

6. Install the locknut onto the bolt and securely tighten.

NOTE: Caster not shown for clarity.

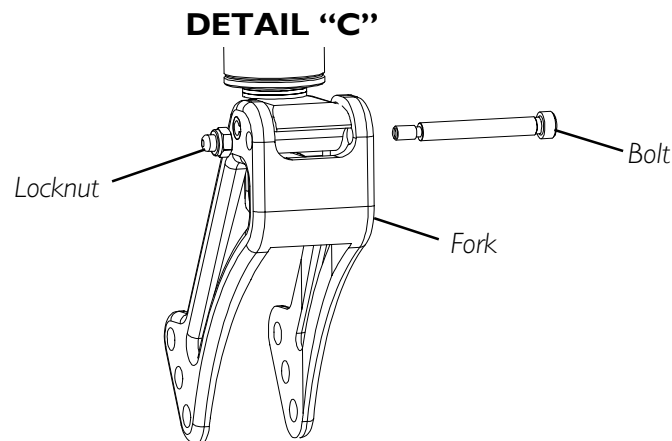
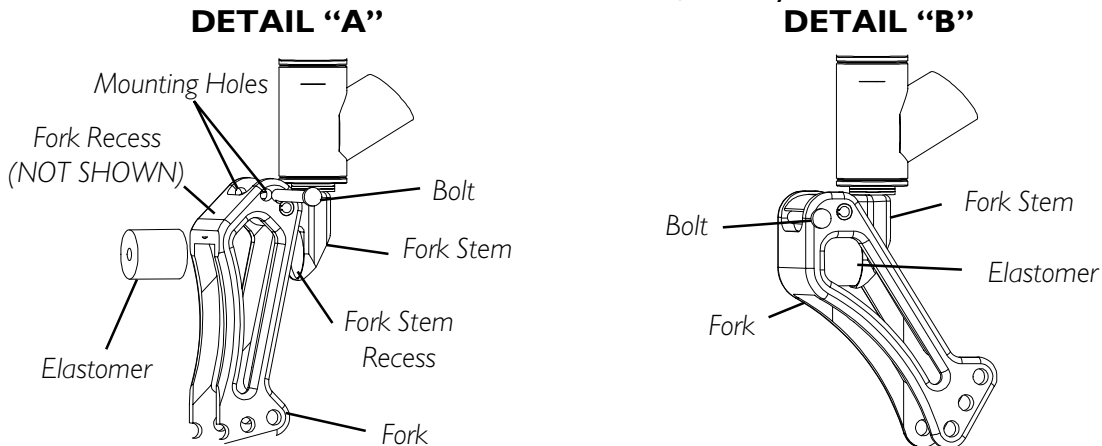

FIGURE 2 - REPLACING FRONT ELASTOMERS

REMOVING/INSTALLING/REPLACING SUSPENSION TUBES (FIGURE 3)

NOTE: Invacare recommends replacing both suspension tubes at the same time to maintain optimum wheelchair performance.

REMOVING SUSPENSION TUBES

1. Remove the rear wheels from the wheelchair. Refer to REMOVING/INSTALLING REAR WHEELS in SECTION 5 of this manual.
2. Note the number of marks showing on the telescoping tube.
3. Open the receiver tube clamps. Refer to OPENING/CLOSING CLAMPS in SECTION 5 of the manual.
4. Pull the suspension tubes with rear axle away from the receiver tube.
5. Note the mounting position of the two (2) mounting screws and locknuts securing the EXISTING suspension tubes to the camber clamp.
6. Remove two (2) mounting screws and locknuts securing each EXISTING suspension tube to camber clamp (DETAIL "B").

INSTALLING SUSPENSION TUBES

1. Secure the NEW suspension tubes to the camber clamps in the position noted in STEP 5 of REMOVING SUSPENSION TUBES with the mounting screws and locknuts (DETAIL "B").
2. Insert the ends of the suspension tubes into the receiver tubes as far as possible.
3. Adjust wheelbase length to the position noted in STEP 2 of REMOVING SUSPENSION TUBES. Refer to ADJUSTING WHEELBASE LENGTH in SECTION 5 of this manual.

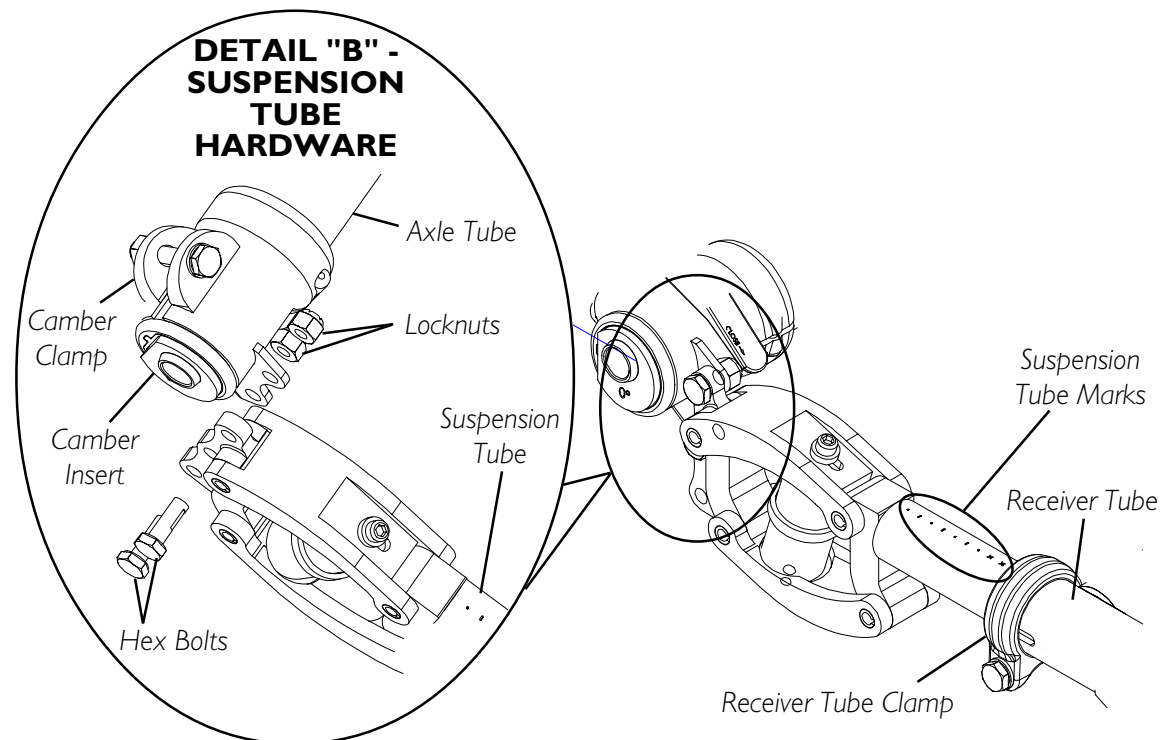

FIGURE 3 - REMOVING/INSTALLING SUSPENSION TUBES

4. Close the receiver tube clamps. Refer to OPENING/CLOSING CLAMPS in SECTION 5 of the manual.
5. Reinstall the rear wheels. Refer to REMOVING/INSTALLING REAR WHEELS in SECTION 5 of this manual.
6. Adjust suspension to correspond to the user's weight. Refer to REPLACING REAR ELASTOMERS in this section of the manual.

ADJUSTING SEAT-TO-FLOOR HEIGHT (FIGURE 4)

WARNING

The position of the footrest, camber tube, back angle, the tautness of the back upholstery as well as the user's condition are directly related to the wheelchair's stability. Any change to one (1) or any combination of the five (5) may cause the wheelchair to decrease in stability. Use **EXTREME** caution when using a new seating position. The addition of anti-tippers may be required. **EXTREME** care **MUST** be taken when changing the stability of the wheelchair. Refer to the chart in STABILITY in SECTION 1 of this manual.

NOTE: Each wheelchair frame has been designed for a specific size rear wheel. Invacare does not recommend changing rear wheel size.

WARNING

Forks for quick release casters are available in different sizes to accommodate spacers. If the wheelchair is equipped with quick release casters, **DO NOT** adjust seat-to-floor height without changing forks.

CHANGE OF SEAT-TO-FLOOR HEIGHT	AXLE TUBE POSITION
LOWER	TOP  UPPER Two (2) Mounting Holes
FACTORY SETTING	MIDDLE  LOWER Two (2) Mounting Holes
HIGHER	BOTTOM  LOWER Two (2) Mounting Holes INVERTED CAMBER CLAMPS

FIGURE 4 - ADJUSTING SEAT-TO-FLOOR HEIGHT

Seat-to-floor height is determined by measuring from the top of the seat rail to the ground/floor.

Several different seat-to-floor heights are possible by using different combinations of caster size, caster position, and axle tube position.

1. Refer to the chart in FIGURE 4 to determine the axle tube position for the desired seat-to-floor height adjustment.
2. Adjust the axle tube position. Refer to REPOSITIONING THE AXLE TUBE in this section of the manual.

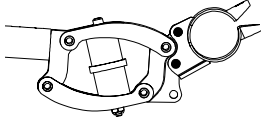
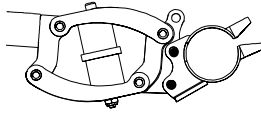
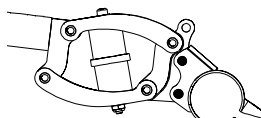
*NOTE: After adjusting the axle tube position, the wheelchair frame **MUST** be parallel to the ground/floor **BEFORE** using. It may be necessary to change caster size, caster position, caster height, wheel lock position and the anti-tipper adjustment (if equipped).*

3. If necessary, refer to REPLACING/ADJUSTING CASTERS in PROCEDURE 5 of the manual to replace the casters or adjust the caster position.
4. After replacing or adjusting the caster size/position, refer to ADJUSTING FRONT CASTER HEIGHT in PROCEDURE 5 of the manual to add/remove fork spacers and add/remove washers to ensure caster headtubes are perpendicular to the ground.
5. Anti-tipper height (if applicable) must be adjusted to maintain 1-1/2 to 2-inch clearance between the bottom of the anti-tipper wheels and the floor. Refer to ANTI-TIPPER REPLACEMENT/ADJUSTMENT in PROCEDURE 6 of this manual.
6. Ensure wheel locks engage properly. Refer to WHEEL LOCK ADJUSTMENT/REPLACEMENT in PROCEDURE 5 of the manual.

NOTE: This seat-to-floor chart is based on pneumatic tires and pneumatic tires with flat free inserts. If wheelchair is equipped with urethane tires, subtract 1/2-inch from the measurements listed below. All heights are approximate to \pm 1/4-inch due to tire wear and air pressure.

REPOSITIONING THE AXLE TUBE (FIGURE 5)

NOTE: This procedure should only be performed if changing the seat-to-floor height. Refer to ADJUSTING SEAT-TO-FLOOR HEIGHT in this procedure of the manual.

NOTE: Right and left are determined by standing behind the wheelchair.

1. Open both the camber clamps. Refer to OPENING/CLOSING CLAMPS in PROCEDURE 5 of the manual.
2. Remove the rear wheels from the wheelchair. Refer to REMOVING/INSTALLING REAR WHEELS in PROCEDURE 5 of the manual.
3. A4 CAMBER SYSTEM ONLY - Remove the camber inserts from the axle tube (FIGURE 5).
4. Refer to ADJUSTING SEAT-TO-FLOOR HEIGHT in this procedure of the manual to determine the proper position for the axle tube.
5. Refer to the chart in DETAIL "C" to determine the proper axle tube adjustment.

NOTE: Refer to DETAIL "B" for suspension tube and clamp hole patterns.

6. Remove the locknuts and hex bolts securing the suspension tubes to the camber clamps.
7. Perform one (1) of the following:
 - A. **CLAMP POSITION MUST BE INVERTED**- Proceed to STEP 8.
 - B. **CLAMP POSITION REMAINS IN STANDARD POSITION** - Proceed to STEP 10.
8. Position the LEFT camber clamp onto the RIGHT end of the axle tube with the metal tabs facing the inside of the wheelchair.
9. Repeat STEP 8 for the RIGHT camber clamp and the LEFT end of the axle tube.

NOTE: The camber clamps should now be inverted, as shown in DETAIL "A".

10. Align the camber clamp mounting holes with the suspension tube holes determined in STEP 5.
11. Secure suspension tube to camber clamp with hex bolts and locknuts.
12. A4 CAMBER SYSTEM ONLY - Insert camber inserts into axle tube with lowest degree of camber facing towards outside of the wheelchair.

13. Install the rear wheels into the camber inserts. Refer to **REMOVING/INSTALLING REAR WHEELS** in PROCEDURE 5 of this manual.

14. Adjust the axle tube. Refer to **ADJUSTING THE AXLE TUBE** in PROCEDURE 5 of this manual.

NOTE: The performance of the wheelchair will be affected if the axle tube has not been adjusted to correct the toe in/toe out of the wheelchair.

15. Ensure the camber clamps are closed. Refer to **OPENING/CLOSING CLAMPS** in PROCEDURE 5 of the manual.

16. Adjust anti-tippers. Refer to **ANTI-TIPPER REPLACEMENT/ADJUSTMENT** in PROCEDURE 6 of the manual.

*NOTE: QUICK RELEASE LEVERS ONLY - Reposition the quick release levers to the top/bottom of the axle tube if desired. Refer to **REPOSITIONING QUICK RELEASE LEVERS** in this procedure of the manual.*

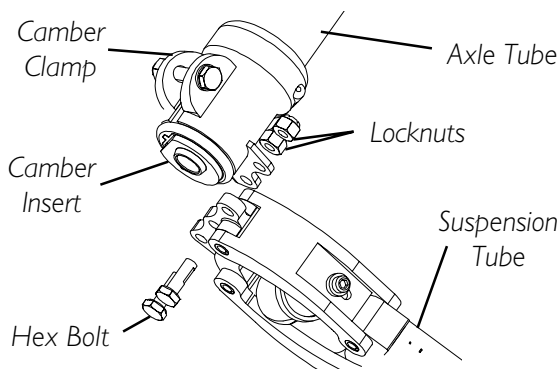

NOTE: LEFT camber clamp and suspension tube not shown for clarity.

DETAIL "A" - CLAMP POSITION

NOTE: Axle tubes are viewed from the FRONT of the wheelchair.

NOTE: Socket facing DOWN not shown for clarity.

STANDARD CLAMP POSITION - TABS/SOCKETS

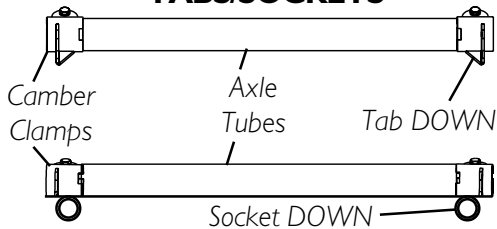

INVERTED CLAMP POSITION - TABS/SOCKETS

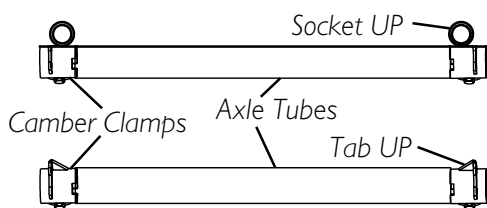

DETAIL "C" - AXLE TUBE POSITIONS

AXLE POSITION	SUSPENSION TUBE HOLE	CLAMP HOLE	CLAMP POSITION*
TOP	A	1	STANDARD
	B	2	Camber Clamp Tab DOWN
MIDDLE	B	1	STANDARD
	C	2	Camber Clamp Tab DOWN
BOTTOM	A	2	INVERTED
	B	1	Camber Clamp Tab UP

NOTE: Tabs on camber clamps shown. Anti-tipper sockets are not shown for clarity.

*NOTE: When viewed from the front of the wheelchair, inside of the rear wheels, an inverted camber clamp has the tab or anti-tipper socket at the top of the axle tube. Refer to **DETAIL "A"**.*

DETAIL "B" - MOUNTING HOLE PATTERN

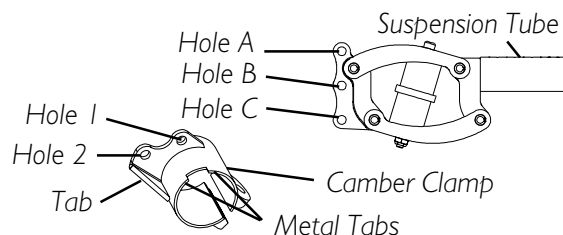
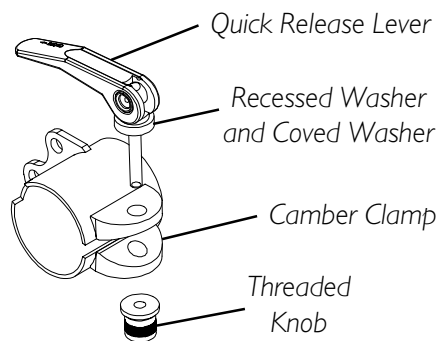

FIGURE 5 - REPOSITIONING THE AXLE TUBE

REPOSITIONING QUICK RELEASE LEVERS (FIGURE 6)

NOTE: This procedure should only be performed if quick release levers are on top of the axle mounting tube and interfere with the desired rear seat-to-floor adjustment. This procedure will position the quick release lever on the bottom of the axle tube.

1. Remove the threaded knob from the quick release lever.
2. Remove the quick release lever, recessed washer and coved washer from the camber clamp.
3. If necessary, position the recessed washer and coved washer onto the quick release lever, as shown in FIGURE 6.
4. Insert the quick release lever with washers through the camber clamp as shown in FIGURE 6.



SIDE VIEW OF CAMBER CLAMP WITH QUICK RELEASE LEVER

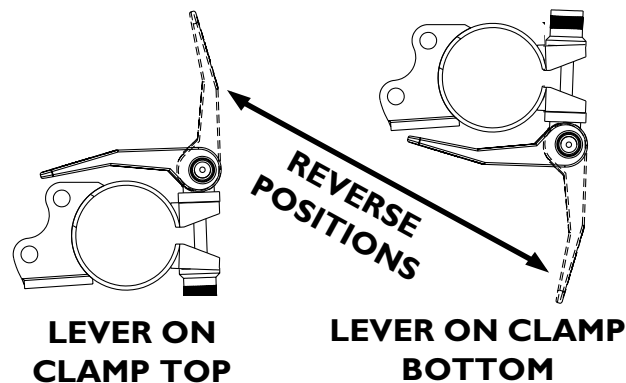

FIGURE 6 - REPOSITIONING QUICK RELEASE LEVERS

LIMITED WARRANTY

PLEASE NOTE: THE WARRANTY BELOW HAS BEEN DRAFTED TO COMPLY WITH FEDERAL LAW APPLICABLE TO PRODUCTS MANUFACTURED AFTER JULY 4, 1975.

This warranty is extended only to the original purchaser/user of our products.

This warranty gives you specific legal rights and you may also have other legal rights which vary from state to state.

Invacare warrants the frame to be free from defects in materials and workmanship for a lifetime of the original purchaser from the date of purchase. All component parts including, but not limited to camber tubes, caster forks, armrests and upholstery are warranted against defects in materials and workmanship for a period of one (1) year from the date of purchase except push handle grips, bushings, bearings, and tires/tubes. If within such warranty period any such product shall be proven to be defective, such product shall be repaired or replaced, at Invacare's option. This warranty does not include any labor or shipping charges incurred in replacement part installation or repair of any such product. Invacare's sole obligation and your exclusive remedy under this warranty shall be limited to such repair and/or replacement.

For warranty service, please contact the dealer from whom you purchased your Invacare product. In the event you do not receive satisfactory warranty service, please write directly to Invacare Top End at the address on the back page. Provide dealer's name, address, date of purchase, indicate nature of the defect and, if the product is serialized, indicate the serial number. Do not return products to our factory without our prior consent.

LIMITATIONS AND EXCLUSIONS: THE FOREGOING WARRANTY SHALL NOT APPLY TO SERIAL NUMBERED PRODUCTS IF THE SERIAL NUMBER HAS BEEN REMOVED OR DEFACED, PRODUCTS SUBJECTED TO NEGLIGENCE, ACCIDENT, IMPROPER OPERATION, MAINTENANCE OR STORAGE, COMMERCIAL OR INSTITUTIONAL USE, PRODUCTS MODIFIED WITHOUT INVACARE'S EXPRESS WRITTEN CONSENT, INCLUDING, BUT NOT LIMITED TO, MODIFICATION THROUGH THE USE OF UNAUTHORIZED PARTS OR ATTACHMENTS; PRODUCTS DAMAGED BY REASON OF REPAIRS MADE TO ANY COMPONENT WITHOUT THE SPECIFIC CONSENT OF INVACARE, OR TO A PRODUCT DAMAGED BY CIRCUMSTANCES BEYOND INVACARE'S CONTROL, AND SUCH EVALUATION WILL BE SOLELY DETERMINED BY INVACARE. THE WARRANTY SHALL NOT APPLY TO PROBLEMS ARISING FROM NORMAL WEAR OR FAILURE TO ADHERE TO THESE INSTRUCTIONS.

THE FOREGOING EXPRESS WARRANTY IS EXCLUSIVE AND IN LIEU OF ANY OTHER WARRANTIES WHATSOEVER, WHETHER EXPRESS OR IMPLIED, INCLUDING THE IMPLIED WARRANTIES OF MERCHANTABILITY AND FITNESS FOR A PARTICULAR PURPOSE, AND THE SOLE REMEDY FOR VIOLATIONS OF ANY WARRANTY WHATSOEVER, SHALL BE LIMITED TO REPAIR OR REPLACEMENT OF THE DEFECTIVE PRODUCT PURSUANT TO THE TERMS CONTAINED HEREIN. THE APPLICATION OF ANY IMPLIED WARRANTY WHATSOEVER SHALL NOT EXTEND BEYOND THE DURATION OF THE EXPRESS WARRANTY PROVIDED HEREIN. THE MANUFACTURER SHALL NOT BE LIABLE FOR ANY CONSEQUENTIAL OR INCIDENTAL DAMAGES WHATSOEVER.

THIS WARRANTY SHALL BE EXTENDED TO COMPLY WITH STATE/PROVINCIAL LAWS AND REQUIREMENTS.



Yes, you can.™

Invacare Corporation www.invacare.com

USA

One Invacare Way
Elyria, Ohio USA
44036-2125
800-333-6900

Invacare Top End
4501 63RD Circle North
Pinellas Park, FL 33781
800-532-8677

Canada

570 Matheson Blvd E Unit 8
Mississauga Ontario
L4Z 4G4 Canada
800-668-5324

Invacare and Top End are registered trademarks of Invacare Corporation. Yes, you can., A4 and Terminator are trademarks of Invacare Corporation.

Dual Grip is a registered trademark of Sun Metal Products, Inc.

KIK is a registered trademark of KIK Technology, Inc.

Spinergy is a registered trademark of Spinergy, Inc.

3-in-1 oil is a registered trademark of American Home Products Corporation.

WD-40 is a registered trademark of WD-40 Company

Loctite 242 is a trademark of the Loctite Corporation.

Teflon is a registered trademark of E.I. Du Pont De Nemours and Company.

© 2003 Invacare Corporation

Part No. 1052712 Rev D - 03/03